



Instructions for Type DBU Expulsion Power Fuses

INSTRUCTIONS FOR INSTALLATION, OPERATION AND MAINTENANCE OF TYPE DBU FUSE UNITS

WARNING

IMPROPER INSTALLATION AND MAINTENANCE OF THESE PRODUCTS CAN RESULT IN DEATH, SERIOUS PERSONAL INJURY AND/OR PROPERTY DAMAGE.

READ AND UNDERSTAND ALL INSTRUCTIONS RELATED TO THIS PRODUCT BEFORE ATTEMPTING INSTALLATION OR MAINTENANCE OF THESE FUSES.

INSTALLATION OR MAINTENANCE SHOULD BE ATTEMPTED ONLY BY QUALIFIED PERSONNEL. THIS INSTRUCTION LEAFLET SHOULD NOT BE CONSIDERED ALL-INCLUSIVE REGARDING THE INSTALLATION OR MAINTENANCE PROCEDURES. IF FURTHER INFORMATION IS REQUIRED, YOU SHOULD CONTACT CUTLER-HAMMER.

THE FUSES DESCRIBED IN THIS LEAFLET ARE DESIGNED AND TESTED TO OPERATE WITHIN THEIR NAMEPLATE RATINGS. OPERATION OUTSIDE OF THESE RATINGS MAY CAUSE THE FUSES TO FAIL, RESULTING IN DEATH, BODILY INJURY AND/OR PROPERTY DAMAGE.

ALL APPLICABLE SAFETY CODES, SAFETY STANDARDS, AND SAFETY REGULATIONS MUST BE STRICTLY ADHERED TO WHEN INSTALLING, OPERATING, OR MAINTAINING THIS EQUIPMENT.

PURPOSE

THESE INSTRUCTIONS COVER THE SAFE INSTALLATION, REPLACEMENT, AND MAINTENANCE OF CUTLER-HAMMER DBU FUSE UNITS WITH CUTLER-HAMMER DBU (OR APPROVED EQUAL) INDOOR OR OUTDOOR DISTRIBUTION MOUNTINGS.

APPROPRIATE END FITTINGS MUST BE CORRECTLY ATTACHED TO THE FUSE UNIT BEFORE IT CAN BE INSTALLED IN A MOUNTING. DBU FUSE UNITS CAN BE INSTALLED IN ANY APPROVED MOUNTING AS LONG AS THE CORRECT END FITTING FOR THE PARTICULAR TYPE OF MOUNTING IS USED. THERE ARE THREE DIFFERENT TYPES OF END FITTINGS FOR USE IN VARIOUS TYPES OF MOUNTINGS.

THE USE OF A PURE SILVER ELEMENT AND NICHROME STRAIN ELEMENTS MAKES THE DBU LESS SUSCEPTIBLE TO OUTAGES CAUSED BY VIBRATION, CORONA CORROSION, AND AGING OF THE FUSE ELEMENTS, NOR IS IT DAMAGED BY TRANSIENT FAULTS OR OVERLOADS WHICH APPROACH THE MINIMUM MELTING POINT.

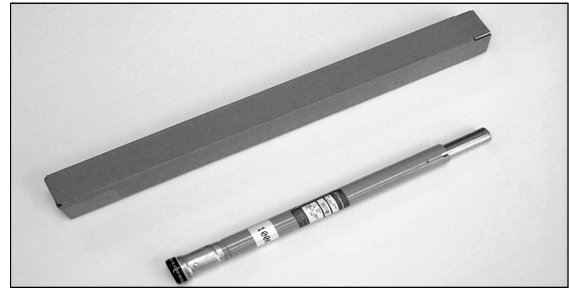

WARRANTY

IT IS THE POLICY OF CUTLER-HAMMER TO HONOR ANY WARRANTY STATEMENT WHEN CUTLER-HAMMER FUSES OR FUSE UNITS ARE USED IN APPROPRIATE END FITTINGS AND/OR FUSE MOUNTINGS NOT MANUFACTURED BY CUTLER-HAMMER. HOWEVER, WARRANTY CAN ONLY BE EXTENDED TO FUSE UNITS OPERATED WITHIN THEIR NAMEPLATE RATINGS IN APPROPRIATE FUSE UNITS AND FUSE MOUNTINGS.

PRECAUTIONS

THOUGH CUTLER-HAMMER DBU FUSE UNITS ARE SEALED, WE RECOMMEND THAT THE UNITS ARE NOT ALLOWED TO HANG INVERTED IN THE OPEN POSITION. THERE IS A REMOTE POSSIBILITY OF SEAL DAMAGE THAT COULD CAUSE MOISTURE INGRESS INTO THE FUSE WHILE IN THIS POSITION, WHICH COULD ADVERSELY AFFECT THE PERFORMANCE OF THE BORIC ACID ARC-QUENCHING SOLID FILLER. STORE FUSE UNITS IN THE ORIGINAL SHIPPING PACKAGE WITH THE INTERNAL PACKAGING INTACT IN AN AREA FREE FROM EXCESSIVE MOISTURE.

END FITTINGS SHOULD ONLY BE ATTACHED IMMEDIATELY PRIOR TO INSTALLATION.

HANDLE FUSE UNITS WITH CARE--DO NOT DROP OR THROW! DO NOT PLACE HAND OVER UPPER SEAL OF FUSE UNIT WHEN HANDLING. (THERE IS A REMOTE POSSIBILITY THE CURRENT-RESPONSIVE SECTION OF THE FUSE UNIT MAY HAVE BEEN WEAKENED IN SHIPPING OR HANDLING. AS A RESULT, THE SPRING-LOADED LATCH-TRIPPING PIN MAY BE UNPREDICTABLY RELEASED AND DRIVEN FORCIBLY THROUGH THE UPPER SEAL.)

DO NOT REMOVE OR LOOSEN THE BLUE LOWER SEAL. IF THE FUSE IS TO BE USED WITH AN EXHAUST CONTROL DEVICE, REMOVE THE BLUE CAP IMMEDIATELY PRIOR TO INSTALLING THE DEVICE.

1. INSTALLATION FOR NEW DBU APPLICATIONS

1.1 Installation (Fusing) in Pad-Mount/Indoor Applications with Exhaust Control Device

Attach fuse-unit end fittings (Fig. 1) as follows:

- A. The lower end fitting must be attached first. Remove and discard the blue cap located on the lower end of the fuse unit. Next, slip the lower end fitting over the upper end of the fuse unit and slide it down until the locating pin on the lower ferrule is seated on the locating pin on the lower ferrule. Then thread the Exhaust Control Device onto the lower end fitting and screw it on firmly. The final fractional turn should be made with a bar or wrench handle.
- B. Slip the upper end fitting over the fuse unit. Align the locating pin (inside the upper end fitting) with the locating slot in the Fuse Unit and seat the upper end fitting firmly against the upper end of the Fuse Unit. Tighten the clamp screw firmly.



CAUTION

ANY AND ALL APPLICABLE SAFETY REGULATIONS MUST BE STRICTLY ADHERED TO CONCERNING THE CLOSURE OR POSSIBLE CLOSURE OF DBU FUSE UNITS ONTO "LIVE" CIRCUITS.

1.1.1 Unused Fuse-Unit End Fittings

A coating of oxidation-inhibiting grease was applied to the contact rod at the factory. Verify the presence of this oxidation-inhibiting grease, and that it is still free of (from) contaminants. If necessary, clean the contact rod with a nontoxic, nonflammable solvent and apply a coating of oxidation-inhibiting grease. End Fittings should be stored in the original shipping package (if possible) in an area free from excessive moisture. End Fittings should only be attached immediately prior to installation.

1.1.2 Re-used Fuse-Unit End Fittings

Remove the existing coating of oxidation-inhibiting grease, and dirt from the contact rod using a nontoxic, nonflammable solvent. Inspect the contact rod for evidence of pitting. If pitting has occurred, file down any projections, abrade the surface, until smooth with an abrasive cloth or scratch brush, and wipe clean. Apply a new coating of oxidation-inhibiting grease, to the contact rod. If the contact has been burned, the contact and its mating part should be replaced.

1.2 Installation (Fusing) in Outdoor Mountings

Attach the fuse-unit end fittings (Fig. 2) as follows:

- A. The lower end fitting must be attached first. Slip the lower end fitting over the upper end of the fuse unit and slide it down until the locating pin seats on the locating pin on the lower Fuse Unit ferrule. Next, back off the locknut on the clamp screw and tighten the clamp screw firmly; secure it with the locknut.
- B. Slip the upper end fitting over the fuse unit. Align the locating pin (inside the upper end fitting) with the locating slot in the Fuse Unit and seat the upper end fitting firmly against the upper end of the Fuse Unit. Tighten the clamp screw firmly. Do not remove the blue outer cap from the bottom of the Fuse Unit.

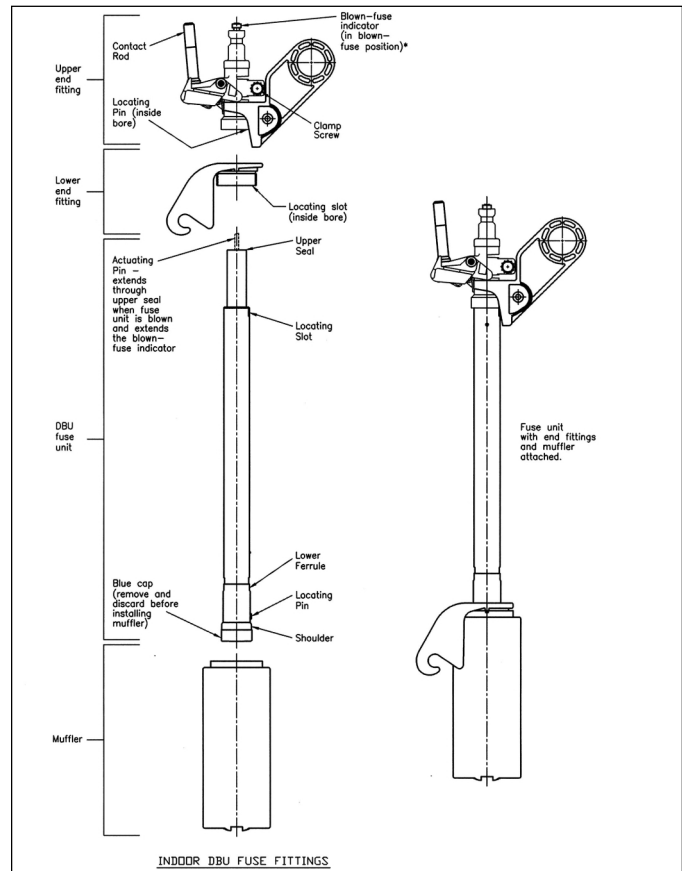

Fig. 1



CAUTION

ANY AND ALL APPLICABLE SAFETY REGULATIONS MUST BE STRICTLY ADHERED TO CONCERNING THE CLOSURE OR POSSIBLE CLOSURE OF DBU FUSE UNITS ONTO "LIVE" CIRCUITS.

1.2.1 Unused Fuse-Unit End Fittings

A coating of oxidation-inhibiting grease was applied to the contact rod at the factory. Verify the presence of this oxidation-inhibiting grease, and that it is still free of (from) contaminants. If necessary, clean the contact rod with a nontoxic, nonflammable solvent and apply a coating of oxidation-inhibiting grease. End Fittings should be stored in the original shipping package (if possible) in an area free from excessive moisture. End Fittings should only be attached immediately prior to installation.

1.2.2 Re-used Fuse-Unit End Fittings

Remove the existing coating of oxidation-inhibiting grease, and dirt from the contact rod using a nontoxic, nonflammable solvent. Inspect the contact rod for evidence of pitting. If pitting has occurred, file down any projections, abrade the surface, until smooth with an abrasive cloth or scratch brush, and wipe clean. Apply a new coating of oxidation-inhibiting grease, to the contact rod. If the contact has been burned, the contact and its mating part should be replaced.

2. REPLACEMENT OF EXISTING APPLICATIONS

2.1 Replacement (Refusing) in Pad-Mount/Indoor Applications with Exhaust Control Device

- A. When the fuse operates, the fuse unit does not swing open but the blown-fuse indicator moves to the extended position, providing visual evidence that the Fuse Unit has operated. Move the Fuse Unit to the open position and then remove it from the mounting. Note: Non-loadbreak mountings do not incorporate a live switching device. Hence, an unblown DBU Fuse Unit in such mountings must not be moved to the open position without first opening an upstream series interrupting and isolating switch or load-break elbow.
- B. Loosen the upper end fitting clamp screw, and pry the clamp apart slightly using a screwdriver. Slide the upper end fitting off the upper end of the Fuse Unit. Then unscrew and remove the Exhaust Control Device. Slide the lower end fitting off the upper end of the Fuse Unit. (Refer to Figure 1.)
- C. Attach the end fittings and muffler to a new Fuse Unit, following the instructions given above. A Fuse Unit that has operated cannot be salvaged. Discard it.
- D. To avoid delay due to transferring of end fittings, spare sets of end fittings and exhaust control devices may be kept on hand for attachment to new Fuse Units immediately before re-fusing is to be performed.



ANY AND ALL APPLICABLE SAFETY REGULATIONS MUST BE STRICTLY ADHERED TO CONCERNING THE CLOSURE OR POSSIBLE CLOSURE OF DBU FUSE UNITS ONTO "LIVE" CIRCUITS.

THE USE OF A PURE SILVER ELEMENT AND NICHROME STRAIN ELEMENT MAKES THE DBU LESS SUSCEPTIBLE TO OUTAGES CAUSED BY VIBRATION, CORONA CORROSION, AND AGING OF THE FUSE ELEMENTS, NOR IS IT DAMAGED BY TRANSIENT FAULTS OR OVERLOADS WHICH APPROACH THE MINIMUM MELTING POINT.

2.2 Replacement (Refusing) in Outdoor Mountings

- A. When the fuse operates, the Fuse Unit swings to the open position. Remove it from the mounting, using a universal pole equipped with a suitable fuse handling attachment. Examine the end of the fuse unit to determine that the actuating pin (see Figure 2) extends through the upper seal, indicating that the fuse unit has operated.
- B. Loosen the upper and lower end fitting clamp screws (pry the upper end fitting clamp apart slightly with a screwdriver), and slide both end fittings off the upper end of the Fuse Unit.
- C. Next, attach the end fittings to a new Fuse Unit, following the instructions given on above. A Fuse Unit that has operated cannot be salvaged. Discard it.
- D. To avoid delay due to transferring of end fittings, spare sets of end fittings may be kept on hand for attachment to new Fuse Units immediately before re-fusing is to be performed.

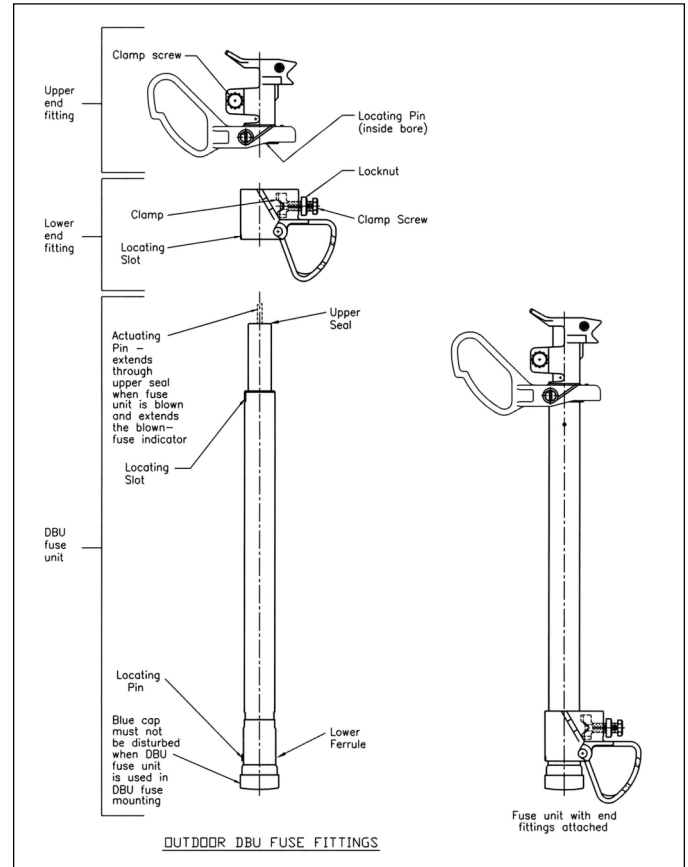

Fig. 2



ANY AND ALL APPLICABLE SAFETY REGULATIONS MUST BE STRICTLY ADHERED TO CONCERNING THE CLOSURE OR POSSIBLE CLOSURE OF DBU FUSE UNITS ONTO "LIVE" CIRCUITS.

2.2.1 Unused Fuse-Unit End Fittings

A coating of oxidation-inhibiting grease was applied to the contact rod at the factory. Verify the presence of this oxidation-inhibiting grease, and that it is still free of (from) contaminants. If necessary, clean the contact rod with a nontoxic, nonflammable solvent and apply a coating of oxidation-inhibiting grease. End Fittings should be stored in the original shipping package (if possible) in an area free from excessive moisture. End Fitting should only be attached immediately prior to installation.

2.2.2 Re-used Fuse-Unit End Fittings

Remove the existing coating of oxidation-inhibiting grease, and any dirt from the contact rod using a nontoxic, nonflammable solvent. Inspect the contact rod for evidence of pitting. If pitting has occurred, file down any projections, abrade the surface, until smooth with an abrasive cloth or scratch brush, and wipe clean. Apply a new coating of oxidation-inhibiting grease, to the contact rod. If the contact has been burned, the contact and its mating part should be replaced.

This instruction leaflet is published solely for information purposes and should not be considered all-inclusive. If any further information is required, please consult Cutler-Hammer.

Sale of product shown in this literature is subject to terms and conditions outlined in appropriate Cutler-Hammer selling policies or other contractual agreement between the parties. This literature is not intended to and does not enlarge or add to any such contract. The sole source governing the rights and remedies of any purchaser of this equipment is the contract between the purchaser and Cutler-Hammer.

NO WARRANTIES, EXPRESSED OR IMPLIED, INCLUDING WARRANTIES OF FITNESS FOR A PARTICULAR PURPOSE OR MERCHANTABILITY, OR WARRANTIES ARISING FROM COURSE OF DEALING OR USAGE OF TRADE, ARE MADE REGARDING THE INFORMATION, RECOMMENDATIONS, AND DESCRIPTIONS CONTAINED HEREIN.

In no event will Cutler-Hammer be responsible to the purchaser or user in contract, in tort (including negligence), strict liability or otherwise for any special, indirect, incidental, or consequential damage or loss whatsoever, including but not limited to damage or loss of equipment, plant or power system, cost of capital, purchaser or user by its customers resulting from the use of the information, recommendations, and descriptions contained herein.

Cutler-Hammer

Pittsburgh, Pennsylvania U.S.A.