

## A BROAD RANGE OF **VISUAL SIGNALING OPTIONS** FOR HAZARDOUS LOCATIONS.

In addition to high-intensity XLT technology, Federal Signal offers a variety of time-tested hazardous area signals to meet any demand.



> **225X** A compact, economical rotating warning light designed for a variety of industrial applications, featuring an innovative design for easy access.



> **121X** A rotating explosion-proof light with 90 flashes per minute and uses a synchronous motor to provide a 360° rotating beam in a horizontal plane.



> **225XST** A hazardous location strobe light, the 225XST is UL-certified as meeting type 4X water tight and corrosion resistant requirements.



> **27XST** An explosion-proof strobe light designed to provide greater compatibility with factory automation control systems.



> **151XST** A rugged strobe light that produces 80 high intensity flashes per minute and meets water-tight, dust-tight and corrosion-resistant requirements.



> **FB2PSTX** A lighting bolt flash of this explosion-proof light is suitable for any application where a superior visual signal is needed and is especially effective for warning.



> **191X** A steady burning light for wherever a visual signal is needed, this fixture can be used for status indication or area lighting.



> **371DST** With 80 flashes per minute and 1,000 effective candlepower, the Commander™ is a double-flash strobe housed in a Type 4X enclosure.



> **USIX** Single-high status indicator that can produce 3 or 4 colors offers a choice of 4 integrated flash patterns – steady-burn, slow flash, strobe flash and SimuStrobe™.



> **WV450XD** A strobe light composed entirely of Glass-Reinforced Polyester (GRP) designed to serve the needs of rugged land-based and offshore industrial applications.

**LED** SIGNALING FOR HAZARDOUS ENVIRONMENTS

The Brightest Ideas  
in LED Signaling for  
Hazardous Environments

# INTRODUCING FEDERAL SIGNAL **LED** WITH **XLT** TECHNOLOGY.

The most trusted name in hazardous area signaling just got better, brighter and longer lasting.

That's because only Federal Signal offers new XLT – **eXtreme Light Technology** – a high-intensity LED array that optimizes light output with superior lens fill.

- Optimized light output
- Extreme vibration resistance
- Extended service life
- Reduced power consumption
- Suitable for DC and AC voltages
- Can be configured for steady burn or flashing



## >225XL

Ideal for wet, corrosive atmospheres or anywhere a vibration-resistant visual signal is needed, the 225XL features a polyurethane-coated base, with an easy-to-remove outer dome for access while changing the lamp or inspecting the unit.

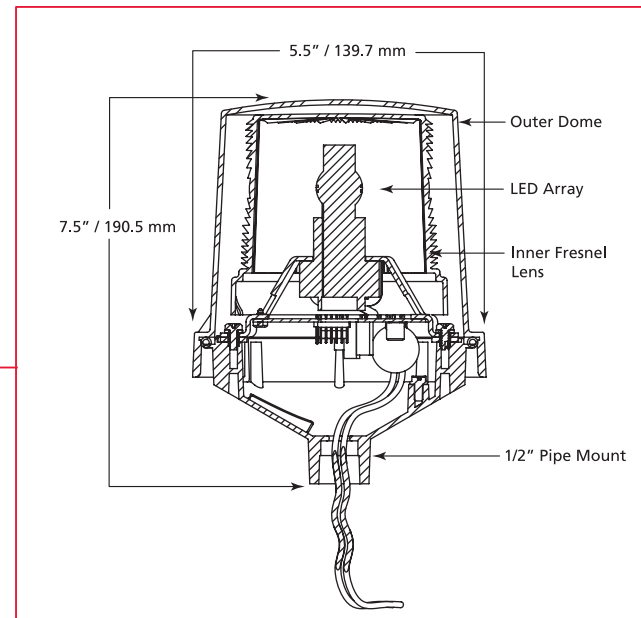

## >27XL

Specifically designed for explosion-proof atmospheres and corrosive environments, the 27XL's all-aluminum housing is easy to install as a pendant or ceiling mount, and it requires very low maintenance.

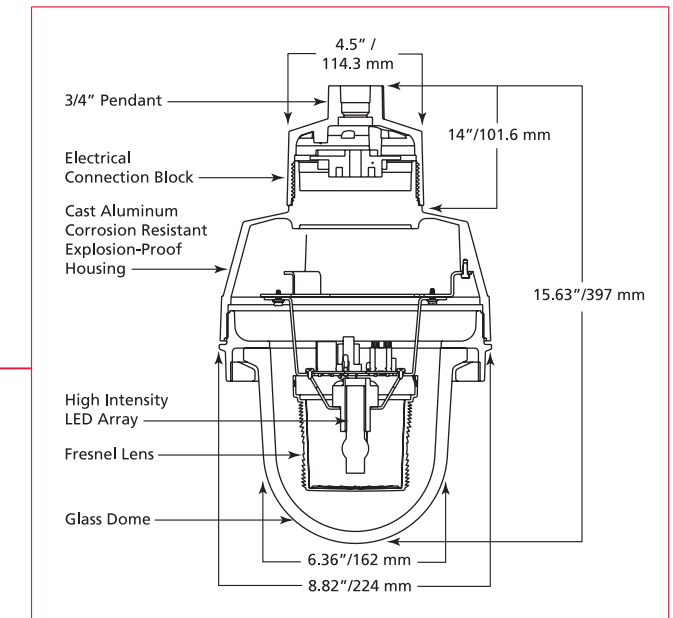

## >191XL

A hazardous location warning light with an aluminum base ready for mounting on a 3/4 inch pipe. A dome guard fits over the glass dome to protect it against accidental collision with moving equipment.

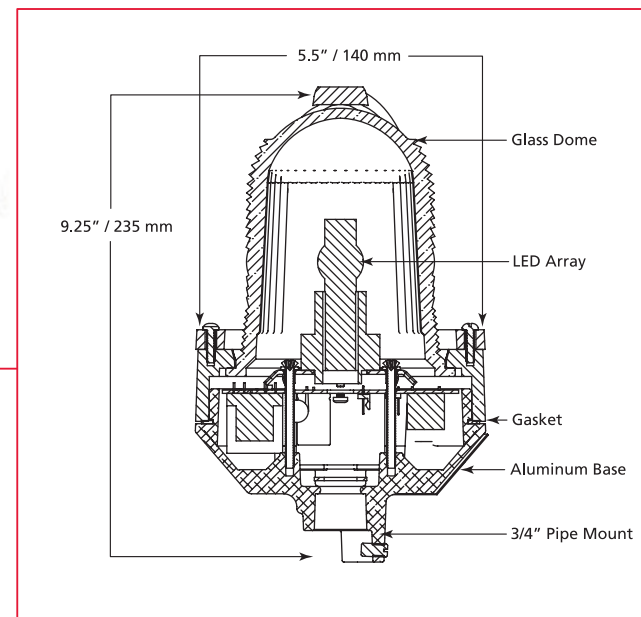

## >2000 LED

An explosion-proof LED warning light, the 2000 LED is available in 6 colors, features 3 remotely selectable flash patterns and is approved for use in Zone 1,2,21,22 atmospheres.

