

Furnas Brand Class 53 Master Switch

4253

Catalog & Price List • May 2010, Replaces April 2007



Class 53

Class 53 Furnas Brand Master Switches are used to provide single handle pilot control of hoists, cranes, oven pushers, car movers and other equipment requiring speed steps of wound rotor or direct current motors.

A special duplex control accessory is available to provide single handle control of two master controls to provide diagonal motion.

They satisfy applications requiring a definite sequence of opening and closing multiple pilot contacts.

Furnas Brand Class 53 Master Switch Standard Features Include:

- Double Break Contacts
- Compact Design
- Momentary or Maintained Contacts
- UL Listed
- CSA Certified

Maintained Contacts - Class 53

DISCOUNT CODE FP

| Speeds | Contacts NO (poles) | Contacts Closed Forward | Contacts Closed Reverse | NEMA 1 Enclosure | |
|--------|---------------------|-------------------------|-------------------------|------------------|---------|
| | | | | Catalog No. | Price |
| 1 | 2 | 1 | 1 | C2542 | \$1,052 |
| 2 | 3 | 2 | 2 | C2374 | \$1,098 |
| 3 | 4 | 3 | 3 | C3331 | \$1,133 |
| 4 | 5 | 4 | 4 | C3330 | \$1,129 |
| 5 | 6 | 5 | 5 | C1950 | \$1,214 |

Momentary Contacts - Class 53

DISCOUNT CODE FP

| Speeds | Contacts NO (poles) | Contacts Closed Forward | Contacts Closed Reverse | NEMA 1 Enclosure | |
|--------|---------------------|-------------------------|-------------------------|------------------|---------|
| | | | | Catalog No. | Price |
| 1 | 2 | 1 | 1 | C2123 | \$1,145 |
| 2 | 3 | 2 | 2 | C2268 | \$1,191 |
| 3 | 4 | 3 | 3 | C2060 | \$1,226 |
| 4 | 5 | 4 | 4 | C4130 | \$1,271 |
| 5 | 6 | 5 | 5 | C1188 | \$1,307 |

Accessories - Class 53

DISCOUNT CODE FP

| Description | Price |
|--|---------|
| NO and NC Contact Operated by Handle Button Add suffix B to the Catalog Number | \$423 |
| Duplex Control L3652XB Requires 2 Master Switches | \$1,314 |

Replacement Parts - Class 53

DISCOUNT CODE FP

| Description | Catalog No. | Price |
|---------------------------------|-------------|-------|
| Contact Board Contacts Included | L14112 | \$85 |

Wiring

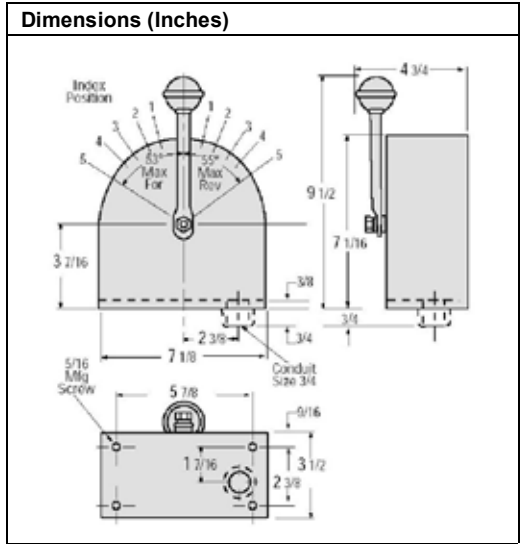
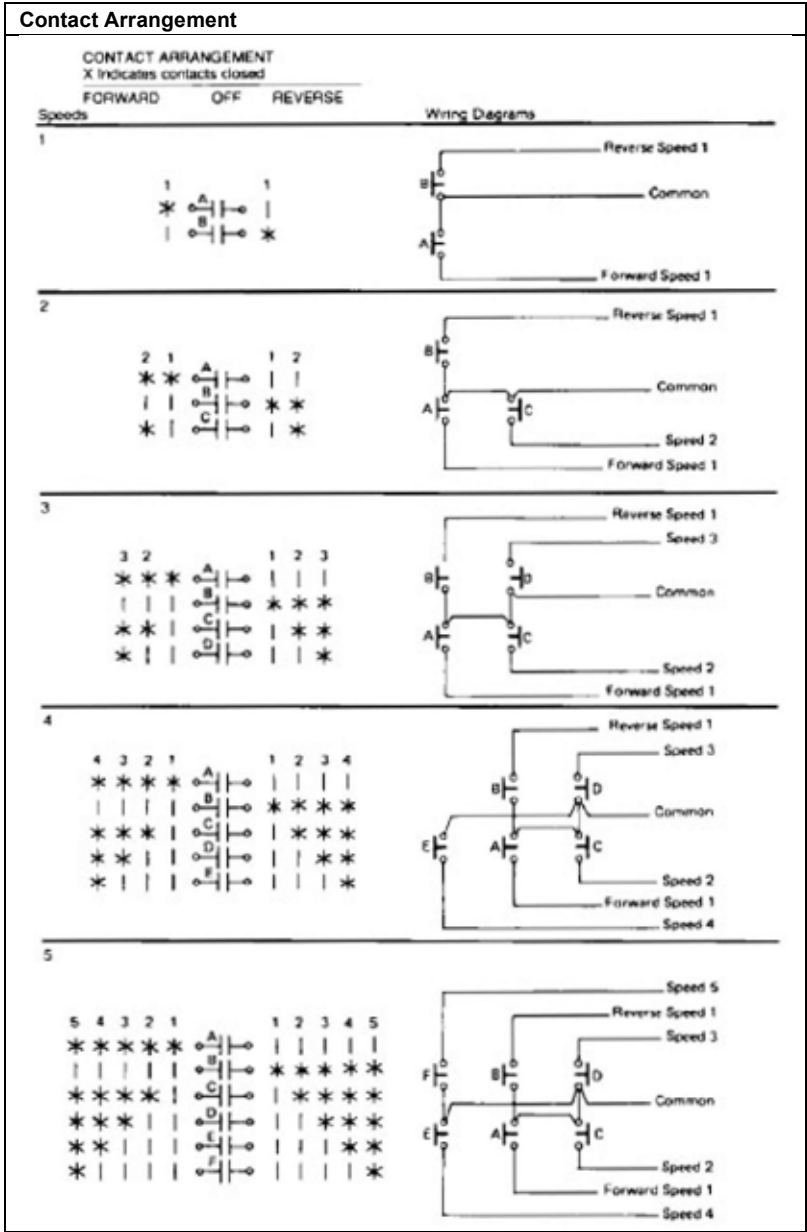

Electrical Ratings

| NEMA A600 10 Continuous Amps (AC) | | |
|-----------------------------------|------|-------|
| Volts | Make | Break |
| 120 | 60 | 6.0 |
| 240 | 30 | 3.0 |
| 480 | 15 | 1.5 |
| 600 | 12 | 1.2 |
| VA | 7200 | 720.0 |

| NEMA A600 10 Continuous Amps (AC) | | |
|-----------------------------------|-------|-------|
| Volts | Make | Break |
| 125 | 1.10 | 1.10 |
| 250 | 0.55 | 0.55 |
| 301-600 | 0.20 | 0.20 |
| VA (300 Volts or less) | 138.0 | 138.0 |



Hubbell Industrial Controls, Inc.
 a subsidiary of Hubbell Incorporated
 4301 Cheyenne Drive, Archdale, NC 27263
 Phone (336) 434-2800 | Fax (336) 434-2801
www.hubbell-icd.com
sales@hubbell-icd.com