



Hubbell Industrial Controls, Inc.

Movable Bridge Control Recommendations

by Ronald W. Hughes

Several different options are available to control the operation of movable bridge structures. The type of control chosen and its implementation are determined to a large degree by the mechanical and structural features of the bridge, and the number and location of the drive motors. Bridge structures are defined by one of three main classifications, and the control systems required to operate these structures can be designed as single or coordinated multiple controls.



Mechanical Classification

The three bridge classifications are Swing, Bascule and Vertical Lift. The number and placement of the drive motors and the mechanical arrangement of the motor and gearing system further subdivides the three classifications.

Swing Bridge

The Swing bridge is a center supported span that rotates horizontally. The mechanical drive arrangement will consist of a large main span gear driven by several smaller pinion gears. Multiple pinion gears are used to distribute the driving torque and to eliminate lateral reaction loads on the main gear bearing. Figures 1 and 2 show two typical motor and gear arrangements.

The gearing arrangement of figure 1 shows multiple motors with independent gear reduction for each motor. Each motor must operate concurrently in order to maintain balanced driving loads on the main gear. The motors will operate at the same speed and are mechanically tied through the main and pinion gear arrangement.

The gearing arrangement of figure 2 is more complex and incorporates intermediate gearing ahead of the final pinion reduction. This arrangement allows the motors to be sized to operate concurrently with shared loads or individually in a main / auxiliary fashion while producing balanced driving loads on the main gear. The motors will operate at the same speed and are mechanically tied through the intermediate gearing in a shared load system. Load sharing and matched operational speeds are not a factor in a main / auxiliary system when the motors are operated singly.

Swing Bridge Motor and Gearing Schematic

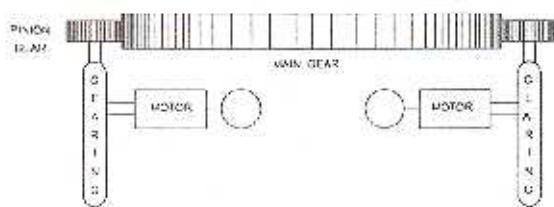

Swing Bridge Drive
2 or More Motors/Span
Independent Gear Reduction
(One Per Motor/Pinion)

Figure 1



Swing Bridge Drive
Dual Motors/Span
Intermediate Gearing
With Dual Final Reduction

Figure 2

Bascule Bridge

The Bascule bridge is characterized by a single leaf or multiple leaves that pivot up from the shore end. Each leaf can be operated by one of the mechanical arrangements shown in figures 3, 4, or 5. The common shaft arrangement shown in figure 3 provides balanced driving torques to the final trunnion gear reduction located on each side of the leaf, and allows the motors to be sized to operate concurrently with shared loads, or individually in a main / auxiliary fashion. The motors will operate at the same speed and are mechanically tied through the intermediate gearing in a shared load system, while, once again, load sharing and matched operational speeds are not a factor in a main / auxiliary system when the motors are operated singly.

The intermediate shaft system shown in figure 4 uses two motors of the same size, one located on each side of the leaf. Each motor drives a final trunnion gear reduction located with the motor. An intermediate speed shaft connects the two final gear reducers to provide differential or balancing torques from one side of the leaf to the other. This arrangement, as with the common shaft arrangement of figure 3, allows the motors to be sized to operate concurrently with shared loads or individually in a main / auxiliary fashion. The motors will operate at the same speed and are mechanically tied through the intermediate shaft in a shared load system. Load sharing and matched operational speeds are not a factor in a main / auxiliary system when the motors are operated singly.

The mechanical system shown in figure 5 is termed the Chicago Style arrangement. With this system, two motors of the same size are used to drive the final trunnion gear reduction located with the motor on each side of the leaf. There is no intermediate shaft connecting both sides to distribute and equalize the driving torques. Both motors must operate with shared loads because a single motor can not operate this leaf without producing a twisting moment in the structure.

Bascule Bridge Motor and Gearing Schematics

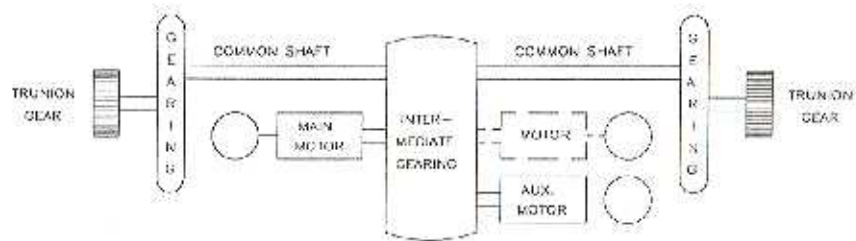

COMMON SHAFT

SINGLE/DUAL MAIN MOTORS
WITH POSSIBLE LOWER HP AUX. MOTOR
INTER-MEDIATE GEARING WITH
DUAL GEAR REDUCERS (ONE PER SIDE)

Figure 3

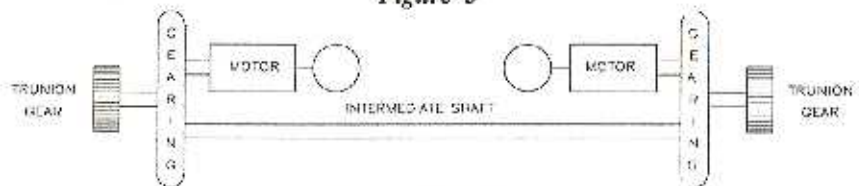

INTERMEDIATE SHAFT

2 MOTORS/LEAF (ONE PER SIDE)
DUAL GEAR REDUCERS (ONE PER SIDE)
WITH COMMON INTERMEDIATE SHAFT

Figure 4



CHICAGO STYLE

2 MOTORS/LEAF (ONE PER SIDE)
INDEPENDANT DUAL GEAR REDUCTION (ONE PER SIDE)

Figure 5



Vertical Lift Bridge

The Vertical Lift bridge is characterized by a horizontal span that is supported by towers at each end. The span is raised vertically between the end towers. Two basic types of mechanical arrangements are used to operate the Vertical Lift bridge. These are the Span Drive and

main / auxiliary system when the motors are operated singly.

The Tower Drive shown in figure 7 uses two driving motors of the same size, one in each tower. Each tower lifts it's end of the span independently. Since the drive

**Vertical Lift Bridge
Motor and Gearing Schematic**

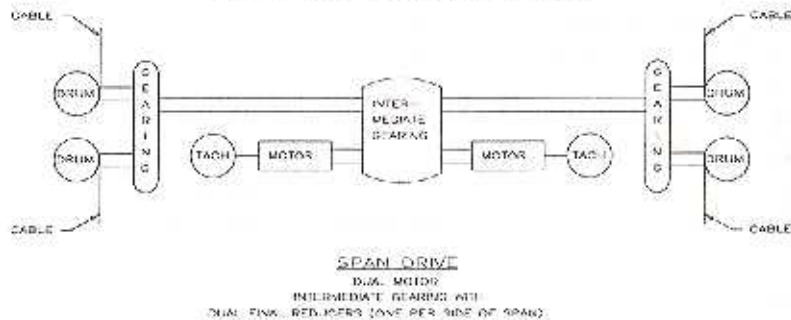

Figure 6

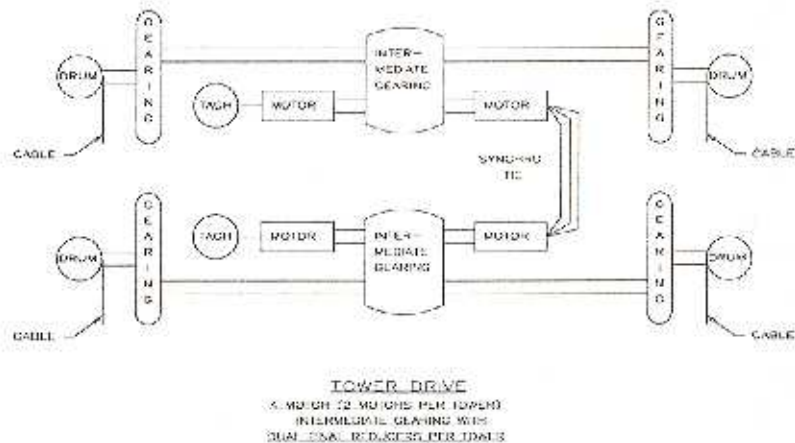

Figure 7

Tower Drive and are shown in figures 6 and 7. The Span Drive shown in figure 6 uses two motors of the same size in a common central location on the span. These motors are connected to a single intermediate gear arrangement, and a common shaft then transmits balanced torques to each side for the final cable drum reduction. This arrangement also allows the motors to be sized to operate concurrently with shared loads or individually in a main / auxiliary fashion. The motors will operate at the same speed and are mechanically tied through the intermediate gearing in a shared load system. Load sharing and matched operational speeds are not a factor in a

motors in each tower are not mechanically tied as in the other bridge gearing arrangements, single motor operation as a main / auxiliary system is not possible. The motors must operate at the same speed in a shared load fashion due to the mechanical nature of the bridge. Two additional motors are often employed in a power synchro-tie configuration which enables balancing and differential torques to be shared tower to tower to prevent skewing and jamming of the span.

Control Options

General

The type of control chosen will be defined by the mechanical attributes of the specific bridge type as described above, or by the special control requirements unique to a given installation. In general, however, the control systems for movable bridges will be designed to operate the drive motors singly, as in a main / auxiliary application, or concurrently in a load sharing arrangement. These control options can be provided by one of four basic systems.

Simplex Control

This design is characterized by a single control system with a speed feedback tachometer and a current transformer dedicated to a single motor. The set-up and operation of this system is simple as no speed or load sharing coordination between multiple motors is required. In multiple motor, main / auxiliary applications where the motors are to be operated individually, a separate dedicated control system will be used for each motor. The block diagram outlining this control system is shown in figure 8.

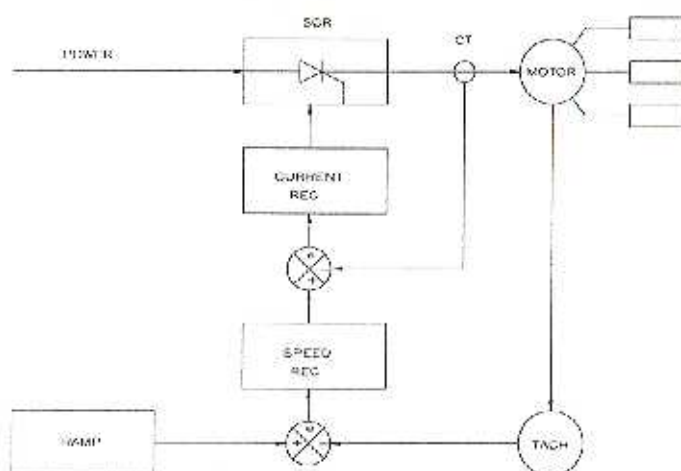

Figure 8
Simplex Control

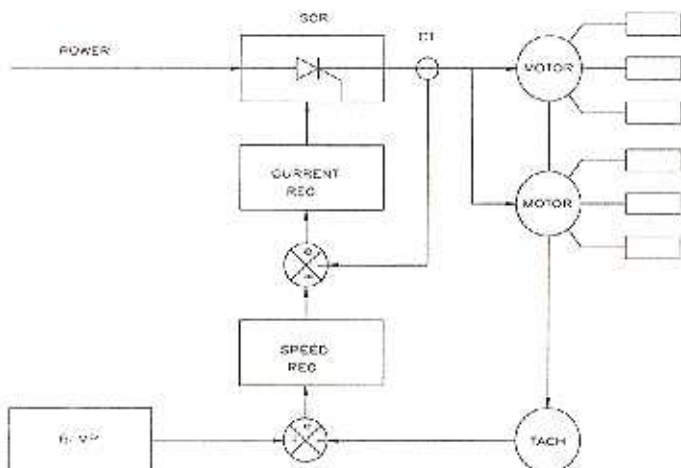

Figure 9
Duplex Control

Mechanical arrangements that can be operated satisfactorily from an adequately sized single motor are candidates for Simplex control. Such arrangements are Swing bridges with intermediate gearing, figure 2, Bascule bridges with intermediate gearing or intermediate shafts, figures 3 and 4, and the Span Drive Vertical Lift bridge with intermediate gearing, figure 6. All of the above configurations have the capability of operating with a single main motor. The second auxiliary control and motor are specified as a back-up system.

Duplex Control

This design is characterized by multiple motors connected to a single control system with a common speed feedback tachometer and current transformer. This system can be used when multiple motors must operate in a shared load arrangement. The single common control

is designed to supply the total power requirements of multiple motors. The motor secondary resistors are adjusted to balance the load sharing between motors. The block diagram outlining this control system is shown in figure 9.

Any multiple motor arrangement with the exception of the Tower Drive Vertical Lift bridge can be operated satisfactorily from a Duplex control. The operation of the Duplex control is identical to the Simplex control presented above and can be used to simplify the operation of multiple motor arrangements when alternate back-up bridge operating schemes are in place.

Master / Slave Control

This design is characterized by multiple motors connected to multiple control systems with individual current transformers and sharing a common system speed feedback tachometer. This system can be used when multiple motors must operate in a shared load arrangement and the control is to supply dynamic current limiting for each motor. The supervising speed regulation function is provided by the master control with an auxiliary speed error signal supplied to the slave control. The block diagram outlining this control system is shown in figure 10.

As with the Duplex control described above, any multiple motor arrangement with the exception of the Tower



Drive Vertical Lift bridge can be operated satisfactorily from a Master / Slave control. The operation and set-up of the Master / Slave system is slightly more involved than the previously described controls due to the added complexity of the Slave control. When the motor sizing and mechanical arrangement permit, the Master / Slave system can operate the bridge with a control power section or individual motor dissabled, thus providing a built in back-up capability.

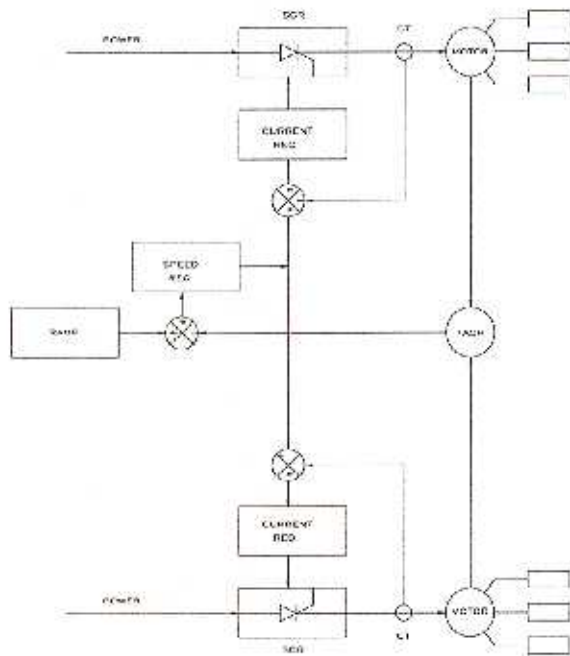

Figure 10
Master Slave Control

Master / Master Control

This design is characterized by several individual control systems, each with a speed feedback tachometer and a current transformer dedicated to a single motor of a multiple motor arrangement. The combined system will share a common speed reference or ramp signal provided by one of the control units. This feature simplifies the system to system speed coordination requirement. The block diagram outlining this control system is shown in figure 11.

Due to the individual speed regulating capabilities of this combined system, it is not recommended for arrangements where the motors are mechanically linked. In mechanically linked multiple motor applications where a span neutral loading condition can exist, the

individual controls of this system can end up fighting for control. This action results in additional loading on the motors and mechanical system.

This system can be used when multiple motors must operate in a shared load arrangement and the controlled motors are not mechanically linked, such as the Tower Drive Vertical Lift bridge. The unique control capabilities of this system permit dynamic skew control between the individual controls.

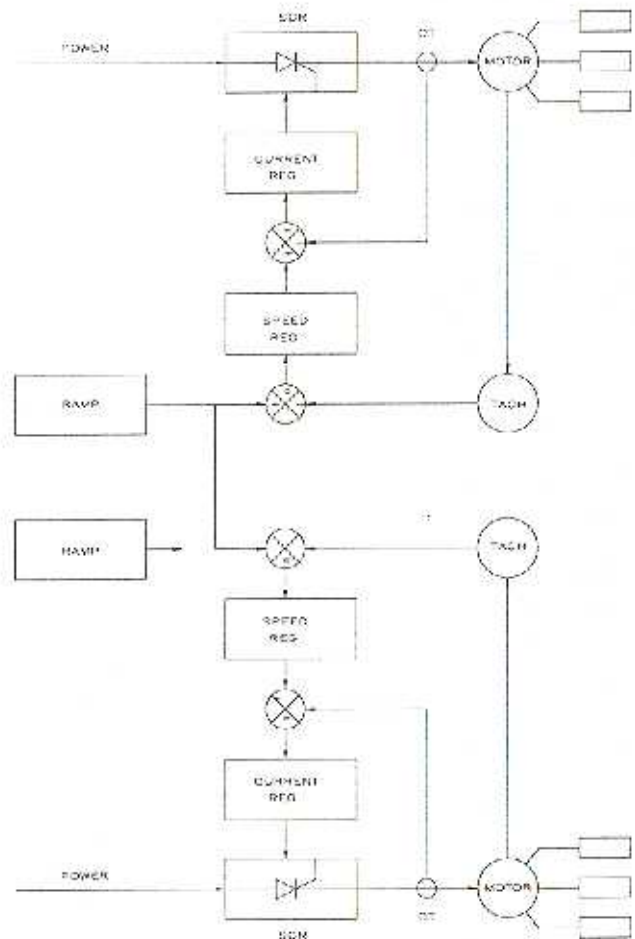

Figure 11
Master/Master Control



Summary

Several options are available for the control of movable bridge structures. The choice and suitability of the individual options will depend upon the mechanical nature of the bridge, and the number and placement of the driving motors. Single motor operation requirements will be best met with a simple Simplex control. Mechanically linked, multiple motors operating in a load sharing ar-

angement can be satisfactorily operated by a Duplex control or a Master / Slave system if individual motor current control is required. The Tower Drive Vertical Lift bridge is best operated with a Master / Master control system using a shared common speed reference ramp. The table shown in figure 12 presents available control options by bridge type.

Bridge Control Summary

Control Type		Swing		Bascule			Vertical Lift	
		Single Motor Main / Aux	Multi Motor Mech Tied	Single Motor Main / Aux	Multi Motor Mech Tied	Multi Motor Chicago	Span Drive	Tower Drive
Single Control	Simplex	X		X				
	Duplex		X		X	X	X	
Multi Control	Master / Slave		X		X	X	X	
	Master / Master							X

Figure 12



Hubbell Industrial Controls, Inc.

a subsidiary of Hubbell Incorporated

50 Edwards St. Madison, Ohio 44057

Telephone (216) 428-1161 Fax (216) 428-7635
