

INSTRUCTION SHEET

For Bulletin 511 Type "S" AC Brake 5-1/2" Brake

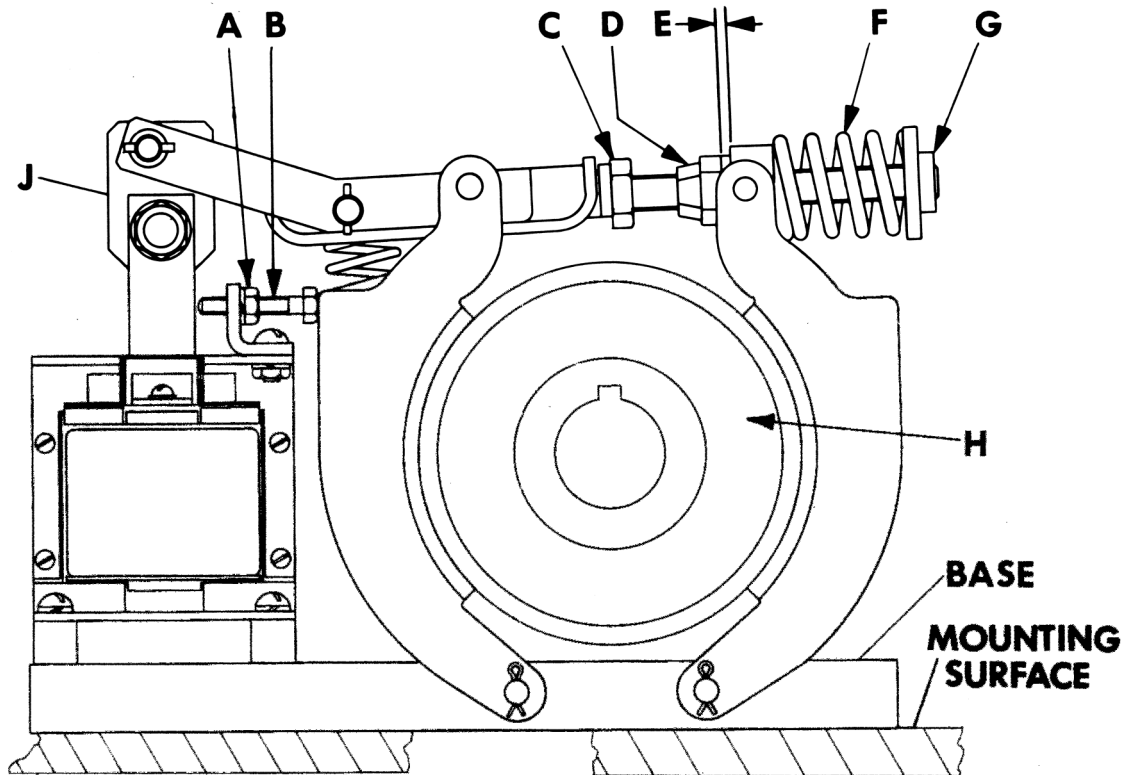

Figure One

1. MOUNTING – Refer to Dimension Drawing

Push the solenoid plunger "J" down to separate the brake shoes. The brake can then be slid over the wheel "H". The center off the wheel should be approximately four (4) inches above the mounting surface. Release the plunger to allow the brake shoes to grip the wheel. Insert shims between the mounting surface and the brake base until the brake is setting solidly on the mounting surface. Then fasten the brake to the stand with proper mounting screws or bolts. Note; These brakes **must** be mounted in a **horizontal** position with the base below the solenoid and shoes.

2. EQUALIZE SHOE CLEARANCE

Push the solenoid plunger "J" down to release the brake wheel "H". Loosen locknut "A", equalize clearance between the shoes and wheel "H": by turning screw "B". When adjustment is completed, tighten locknut "A".

3. TORQUE ADJUSTMENT

The brake is adjusted at the factory to provide the rated torque shown on the nameplate. To set the brake for rated torque, loosen locknut "C" and,

while holding nut "D", turn bolt "G": to obtain the approximate compressed spring length specified below. Retighten locknut "C" and recheck clearance "E". NOTE: After any brake adjustment is made, recheck the shoe to wheel clearance in step no. 2.

4. READJUSTMENT FOR LINING WEAR

As the lining wears, the clearance "E" decreases. Never permit this clearance to become zero because complete loss of torque will result. When the clearance "E" becomes low, re-adjust to .015" by turning nut "D". Locknut "C" prevents the shaft from rotating when this adjustment is performed. No change in torque will result from this adjustment. NOTE: Brake linings should be renewed before the groove pins are allowed to contact the wheel face. Repeat step no. 2.

TORQUE ADJUSTMENT

Size Of Brake	Torque Rating	Compressed Length of Spring "F"
5-1/2"	25 Lbs. Ft.	2.10"
	35 Lbs. Ft.	1.90"

RENEWAL PARTS

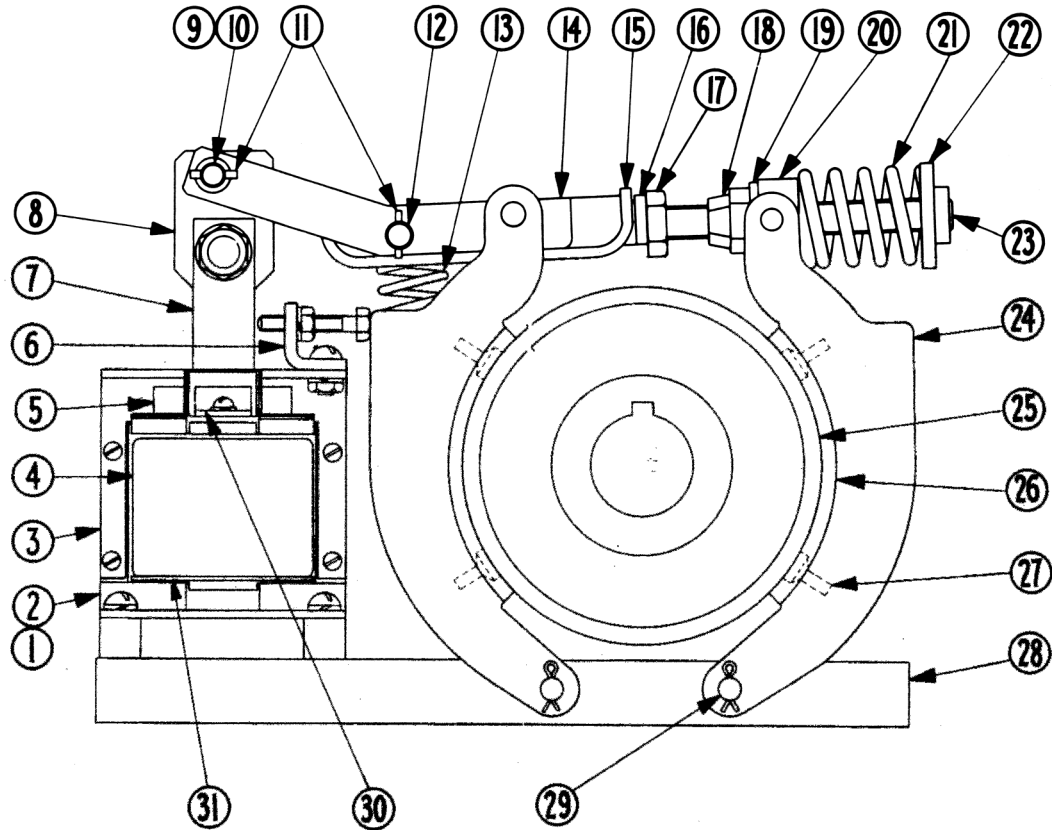

Item No.	Description Of Part	No. Req.	Part No.	Item No.	Description Of Part	No. Req.	Part No.
1	Case (when used)	1	39-16564	16	Adjusting stud nut	1	15-1894
2	Case (when used)	1	47-828	17	1/2-13 Hex nut	1	915-1401Z
3	Frame	1	17-476	18	Locknut 1/2-13	1	15-610
* 4	Coil (Give No. on Coil)	1	19	Washer	1	916-1201Z
5	Spring	2	69-273	* 20	Pivot block.....	1	17-16951
6	Bracket	1	79-415	21	Torque spring	1	69-287
	1/4 Helical washer.....	1	916-682Z	22	Cup washer	2	16-3424
	1/4-20 X 1.5 RH Screw.....	1	911-5452Z	23	Adjusting bolt	1	11-4719
	1/4-20 Hex Nut	1	915-24Z	24	Brake shoe (includes items 26 and 27)	2	48-1787
* 7	Plunger	1	51-93-12	# 25	Brake Wheel (see below)	1
8	Link	1	51-2220	26	Lining	2	48-1605
9	Pin	1	13-7638	27	Groove Pin	8	13-4762
10	Spacer	3	56-2561-4	28	Base	1	17-242
11	Spring Pin	4	13-3187-2	29	Base pin.....	2	13-474
12	Pin	1	13-317-9	30	Plunger guide	2	54-300-2
* 13	Solenoid Spring	1	69-4575	31	Washer	2	16-254
14	Lever	2	24-7534	* 32	Lining Kit (Includes items 26 and 27)	1	6-166-2
15	Spring Gland	1	49-5637	33	Solenoid w/o coil (includes items 3, 5, 7, 8, 30, & 31)	1	88-2930-4

* - We recommend these items be stocked. The quantity to be stocked will depend upon the total number of brakes in use.
 # - Give 511H number stamped on wheel or, if this number does not appear on the wheel, give complete nameplate data and bore with keyway dimensions.