

Air Conditioning Disconnects

Air Conditioning Disconnects



7.1 Air Conditioning Disconnects

Product Description	2
Application Description	2
Features, Benefits and Functions	3
Standards and Certifications	3
Product Selection	4
Cross-Reference	6
Technical Data and Specifications	7
Dimensions	7



7.1

Air Conditioning Disconnects

Fused, Unfused and Molded Case Switch

Air Conditioning Disconnects



Complete Line of Fused, Unfused and Molded Case Switch Type Air Conditioning Disconnects

7

Contents

<i>Description</i>	<i>Page</i>
Features, Benefits and Functions	3
Standards and Certifications	3
Product Selection	4
Cross-Reference	6
Technical Data and Specifications	7
Dimensions	7

Product Description

An air conditioning disconnect (ACD) is a disconnect located between a loadcenter (distribution panel) and air conditioner. Eaton's ACD product line provides an installer or repair personnel with a visible disconnecting means when performing maintenance. ACDs are also known as disconnects, pullouts or air conditioning switches.

Non-fused pullout and molded case switch devices provide personnel with a visible ON-OFF disconnecting means. While fused pullout units also perform this function, they also provide an additional level of protection for the air conditioner.

Fused and non-fused devices are of a pullout design, where the user physically removes or "pulls out" a tab to break the electrical connection. A molded case switch is similar to a light switch where the user "switches" the unit to the indicated ON-OFF position.

Fused and Non-Fused Pullouts

- ON/OFF control provided by a pullout handle
- Pullout handle can be conveniently stored in the compartment in the OFF position, helping to prevent the handle from being misplaced
- Protective shield cannot be removed until the pullout handle is removed, disconnecting the power

Molded Case Switch

- Rugged molded case construction in a disconnect switch that looks like a circuit breaker but operates like an ordinary household light switch
- Plug-in molded case switch (included) eliminates the need for pullout handles
- No need for replacement pullout handles due to loss or theft

Application Description

The most widely used application for ACDs is for residential and light commercial air conditioning units. An ACD is installed outdoors, in visible proximity to the air conditioner condensing unit. ACDs are also found in use with heat pumps, swimming pools, spas, whirlpools and pump houses, and meet 2008 NEC Article 422.31 (B) requirements for servicing electric water heaters. Metallic enclosures are galvanized steel and are installed in various locations. Non-metallic enclosures are a plastic (polycarbonate) enclosure commonly used in coastal or salt-water areas.

Features, Benefits and Functions

- Single-phase, two-wire, 240 Vac and three-phase, three-wire, 240 Vac
- NEMA® 3R outdoor enclosures offered in metallic and non-metallic versions
- Easy-to-remove high-strength protective shield for easier wiring and mounting
- Easy-to-remove front cover (no screws or fasteners to remove)
- 1-inch knockouts on the bottom, back and side of unit
- Copper-rated line and load lugs that are easily accessible
- Ample wiring space for mounting with a stud gun (single keyhole, two- or three-point mounting)
- Fused devices are service entrance rated
- Horsepower rated (10 hp maximum at 240 Vac)
- Padlockable door provision for safety and reduction of tampering
- Metallic enclosures are bottom entry and exit only
- Non-metallic enclosures have knockouts and a hub provision for top access
- Non-metallic enclosures have a single unit door and protective shield for installer convenience
- Non-metallic enclosures are durable and provide excellent resistance to climate changes
- Factory-installed tamper-resistant/weather-resistant receptacles are available as an option on some products

Note: Fused non-metallic units require the addition of **GB4NM** ground bar to obtain a Service Entrance rating.

Standards and Certifications

- UL® listed File No. E132354, E143893, E196365

Contact Eaton for details and part numbers for CSA approved units.



7.1

Air Conditioning Disconnects

Fused, Unfused and Molded Case Switch

Product Selection

DPU222R



Non-Fused Pullouts

Main Ampere Rating	Maximum hp Rating		Wire Size Range Cu/Al 60°C or 75°C	Catalog Number
	120V	240V		
Galvanized Steel				
60	3	10	#14-3	DPU222R ①
Non-Metallic/Polycarbonate Enclosure				
60	3	10	#14-2	ACD222URNM-A2 ①

7

DPF222R



Fused Pullouts

Main Ampere Rating	Maximum hp Rating		Wire Size Range Cu/Al 60°C or 75°C	Catalog Number
	120V	240V		
Galvanized Steel				
30 ②	1-1/2	3	#14-3	DPF221R ①
60 ②	3	10	#14-3	DPF222R ①
Non-Metallic				
30 ③	1-1/2	3	#14-2	ACD221RNMM-A2 ①
60 ③	3	10	#14-2	ACD222RNMM-A2 ①

For Service Entrance applications, see footnotes below.

DPB222R



Molded Case Switch

Main Ampere Rating	Maximum hp Rating		Wire Size Range Cu/Al 60°C or 75°C	Catalog Number
	120V	240V		
Galvanized Steel				
60	—	10	#14-3	DPB222R ④
Non-Metallic/Polycarbonate Enclosure				
60	—	10	#14-2	B60NARNM-A2 ④

Notes

- ① For replacement pullout head, order part number **96-3258-4**.
- ② To obtain a Service Entrance Rating, the addition of a **DPFG** (ground bar kit) is required.
- ③ To obtain a Service Entrance Rating, the addition of a **GB4NM** (ground bar kit) is required.
- ④ For replacement molded case switch, order part number **BR260NA**.

DPU222RGF20

**ACD with 20 Ampere Ground Fault Receptacle** ①

Main Ampere Rating	Maximum hp Rating		Wire Size Range Cu/Al 60°C or 75°C	Catalog Number
	120V	240V		
Non-Fused Pullouts				
60	3	10	#14-3	DPU222RGF20WRTR ②
60	3	10	#14-3	DPU222RGF20
Fused Pullouts				
30	3	10	#14-3	DPF221RGF20WRTR ②
30	3	10	#14-3	DPF221RGF20
60	3	10	#14-3	DPF222RGF20WRTR ②
60	3	10	#14-3	DPF222RGF20

DPU222RGF15

**ACD with 15 Ampere Ground Fault Receptacle** ①③

Main Ampere Rating	Maximum hp Rating		Wire Size Range Cu/Al 60°C or 75°C	Catalog Number
	120V	240V		
Non-Fused Pullouts				
60	3	10	#14-3	DPU222RGF15
60	3	10	#14-3	DPU222RGF15WRTR ②
Fused Pullouts				
30	3	10	#14-3	DPF221RGF15
30	3	10	#14-3	DPF221RGF15WRTR ②
60	3	10	#14-3	DPF222RGF15
60	3	10	#14-3	DPF222RGF15WRTR ②

Notes

- ① Factory-installed GFCI receptacle.
 ② Includes weather-resistant/tamper-resistant receptacles to meet 2008 NEC Article 406.8 (A) and 406.11 requirements.
 ③ NEC permits the maximum receptacle rating of a 15A circuit to be 15A.

7.1

Air Conditioning Disconnects

Fused, Unfused and Molded Case Switch

DPU222R12W



ACD with Factory-Installed Whip—Non-Fused Pullout ①

Whip Diameter	Hot Wire Size	Ground Wire Size	Flexible Conduit Length	Non-Metallic Fittings	Catalog Number
1/2 Inch	#10	#10	6 ft (1.8m)	1–90°, 1—Straight	DPU222R12W
3/4 Inch	#8	#10	6 ft (1.8m)	1–90°, 1—Straight	DPU222R34W

DPU362R



Three-Phase Non-Fused ACD

Main Ampere Rating	Maximum hp Rating		Wire Size Range Cu/Al 60°C or 75°C	Catalog Number
	120V	240V		
60	10	15	#14–3	DPU362R

7

Cross-Reference

Cross-Reference

Description	Catalog Number					
	Eaton	Square D®	GE®	Siemens® (Murray®)	Milbank	Midwest
Metallic/Galvanized Steel Enclosure						
30A fused	DPF221R	—	TF30R	WF2030	U3830	U035F2
60A fused	DPF222R	—	TF60R	WF2060	U3860	U065F1
60A non-fused	DPU222R	—	TFN60R	—	U3800	U065P010
60A non-fused compact design	DPU222R	—	—	WNFC2060	—	—
60A molded case switch	DPB222R	QO200TR	TNA60R1	WNAS2060	—	U065NA1
60A non-fused with ground fault receptacle	DPU222RGF	—	TFN60RGFR	WN2060GFCI	U3822-20GR	U065P010
30A fused with ground fault receptacle	DPF221RGF	—	—	WF2030GFCI	—	U035F010
60A fused with ground fault receptacle	DPF222RGF	—	—	WF2060GFCI	—	U065F010
60A non-fused with 1/2-inch wire harness	DPU222R12W	—	—	—	—	—
60A non-fused with 3/4-inch wire harness	DPU222R34W	—	—	—	—	—
60A three-phase 600V molded case switch	DPU362R	—	—	—	—	U0653F
Non-Metallic/Polycarbonate Enclosure						
30A fused	ACD221RNM-A2	—	TPF30R	WF2030PL	—	P035F
60A fused	ACD222RNM-A2	—	TPF60R	WF2060PL	—	P065F
60A non-fused	ACD222URNM-A2	—	TPN60R1	WN2060PL	—	P065P1
60A molded case switch	B60NARNM-A2	QO200TRNM	TPNA60R1	WNAS2060PL	—	P065NA1
30A fused with 15A ground fault receptacle	DPF221RGF15WRTR	—	—	—	—	—
30A fused with 20A ground fault receptacle	DPF221RGF20WRTR	—	—	—	—	—
60A fused with 15A ground fault receptacle	DPF222RGF15WRTR	—	—	—	—	—
60A fused with 20A ground fault receptacle	DPF222RGF20WRTR	—	—	—	—	—
60A non-fused with 15A ground fault receptacle	DPU222RGF15WRTR	—	—	—	—	—
60A non-fused with 20A ground fault receptacle	DPU222RGF20WRTR	—	—	—	U3822-20GWR	—

Note

① Eaton Quick ProSM designated item.

Technical Data and Specifications

- 10,000 amperes rms symmetrical interrupting rating
- Horsepower rated
- Fusible and non-fusible pullout and molded case switch designs
- 30 and 60 amperes available in fusible
- 60 amperes available in non-fusible and molded case switch
- Class H fuse clips provided on fusible pullout design
- WRTR (weather-resistant/tamper-resistant) receptacle options available

Dimensions

Approximate Dimensions in Inches (mm)

Dimensions and Shipping Carton Information

Catalog Number	Carton Quantity	Dimensions in Inches (mm)			Weight Lbs (kg)
		Height	Width	Depth	
Metallic/Galvanized Steel Enclosure					
DPF221R	10	8.70 (220.9)	5.40 (137.2)	3.15 (80.0)	27 (12)
DPF222R	10	8.70 (220.9)	5.40 (137.2)	3.15 (80.0)	27 (12)
DPU222R	10	8.70 (220.9)	5.40 (137.2)	3.15 (80.0)	27 (12)
DPB222R	10	8.60 (218.4)	5.30 (134.6)	3.74 (95.0)	34 (15)
DPU222R12W [Ⓢ]	1	14.75 (374.6)	12.50 (317.5)	4.00 (101.6)	6 (3)
DPU222R34W [Ⓢ]	1	14.75 (374.6)	12.50 (317.5)	4.00 (101.7)	6 (3)
DPU222RGF20	1	13.00 (330.2)	7.50 (190.5)	4.75 (120.7)	8 (4)
DPF221RGF20	1	13.00 (330.2)	7.50 (190.5)	4.75 (120.7)	8 (4)
DPF222RGF20	1	13.00 (330.2)	7.50 (190.5)	4.75 (120.7)	8 (4)
DPU222RGF15	1	13.00 (330.2)	7.50 (190.5)	4.75 (120.7)	8 (4)
DPF221RGF15	1	13.00 (330.2)	7.50 (190.5)	4.75 (120.7)	8 (4)
DPF222RGF15	1	13.00 (330.2)	7.50 (190.5)	4.75 (120.7)	8 (4)
DPF221RGF15WRTR	1	13.00 (330.2)	7.50 (190.5)	4.75 (120.7)	8 (4)
DPF221RGF20WRTR	1	13.00 (330.2)	7.50 (190.5)	4.75 (120.7)	8 (4)
DPF222RGF15WRTR	1	13.00 (330.2)	7.50 (190.5)	4.75 (120.7)	8 (4)
DPF222RGF20WRTR	1	13.00 (330.2)	7.50 (190.5)	4.75 (120.7)	8 (4)
DPU222RGF15WRTR	1	13.00 (330.2)	7.50 (190.5)	4.75 (120.7)	8 (4)
DPU222RGF20WRTR	1	13.00 (330.2)	7.50 (190.5)	4.75 (120.7)	8 (4)
DPU362R	1	8.60 (218.4)	5.30 (134.6)	3.74 (94.9)	4 (2)
Non-Metallic/Polycarbonate Enclosure					
ACD221RNM-A2	10	8.63 (219.0)	5.00 (127.0)	3.50 (88.9)	15 (7)
ACD222RNM-A2	10	8.63 (219.0)	5.00 (127.0)	3.50 (88.9)	15 (7)
ACD222URNM-A2	10	8.63 (219.0)	5.00 (127.0)	3.50 (88.9)	15 (7)
B60NARNM-A2	10	8.63 (219.0)	5.00 (127.0)	3.50 (88.9)	18 (8)

Note

[Ⓢ] Eaton Quick Pro designated item.

7.1

Air Conditioning Disconnects

Fused, Unfused and Molded Case Switch

Approximate Dimensions in Inches (mm)

DPF221R, DPF222R, DPU222R, DPU222R12W and DPU222R34W

7

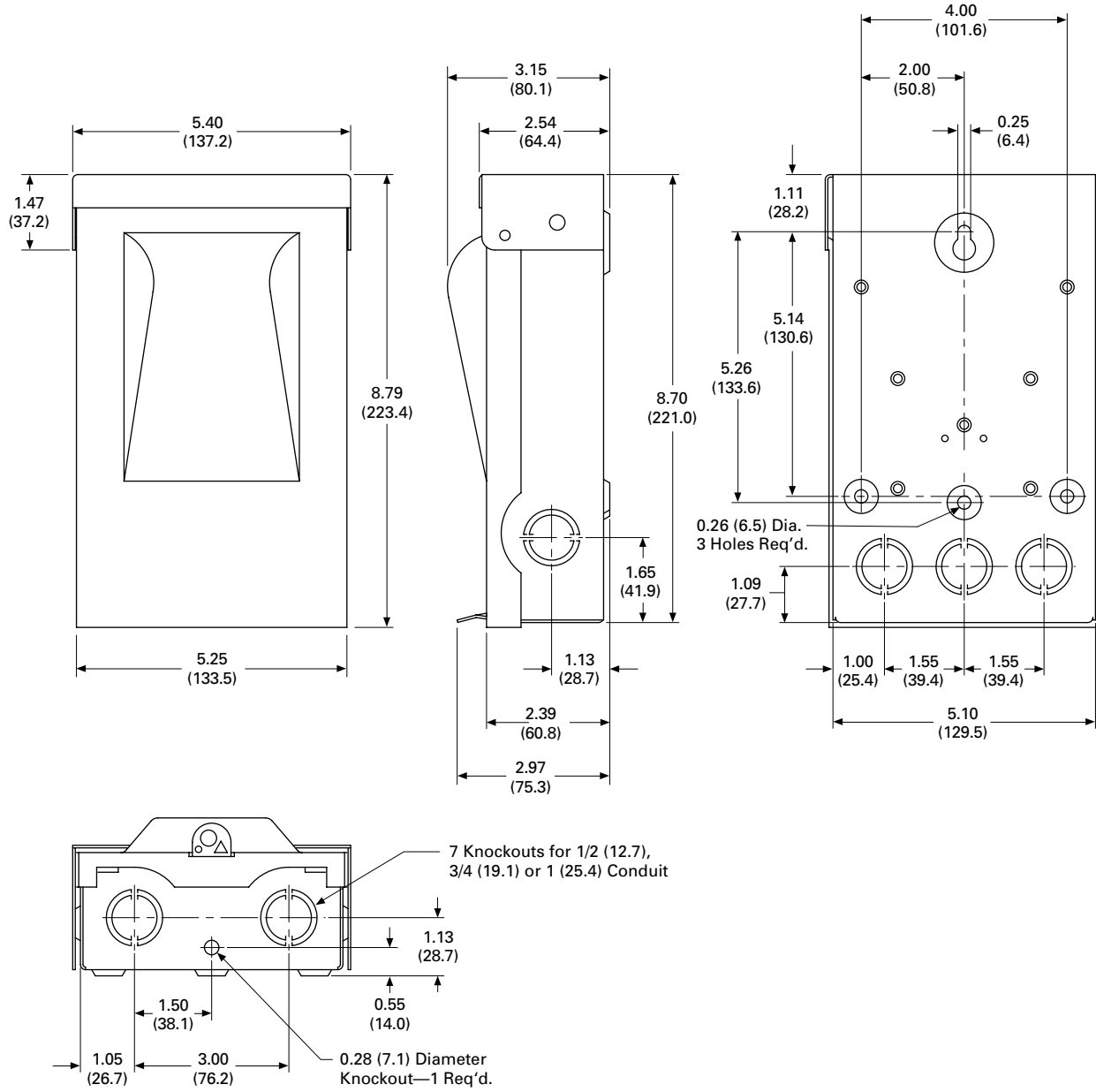

Approximate Dimensions in Inches (mm)

ACD221RNM-A2, ACD222RNM-A2, ACD222URNM-A2 and B60NARNM-A2

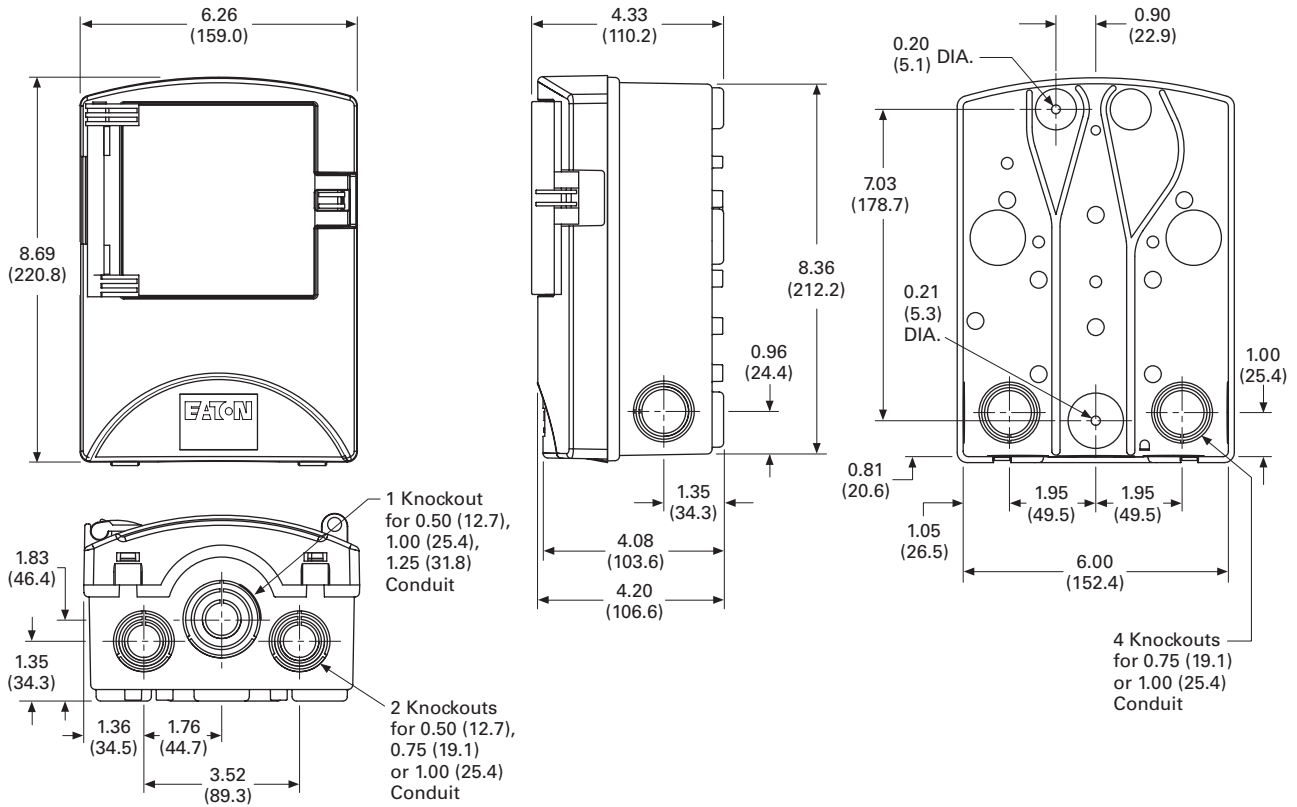

DPB222R and DPU362R

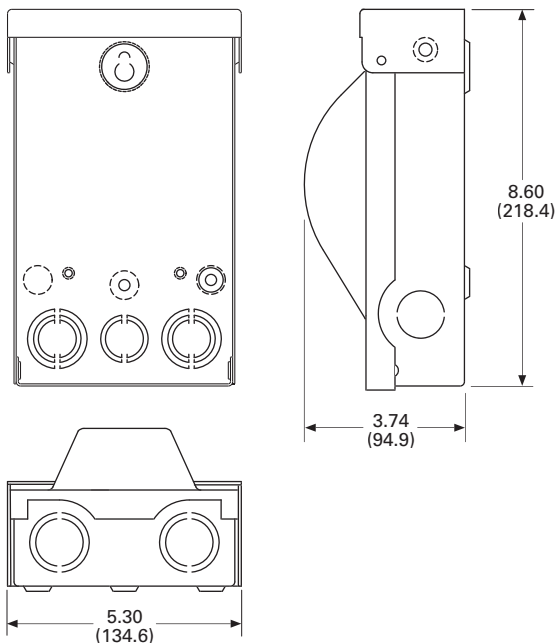

7.1

Air Conditioning Disconnects

Fused, Unfused and Molded Case Switch

Approximate Dimensions in Inches (mm)

DPU222RGF20, DPF221RGF20, DPF222RGF20, DPU222RGF15, DPF221RGF15, DPF222RGF15, DPF221RGF15WRTR, DPF221RGF20WRTR, DPF222RGF15WRTR, DPF222RGF20WRTR, DPU222RGF15WRTR and DPU222RGF20WRTR

