



In This Section...

Blackburn® Compression

Compression Connectors — Quick Reference.....	C-2
Color-Coded Compression Connectors.....	C-3–C-10
Tool and Die Index for Color-Coded Compression Connectors.....	C-11–C-14



Blackburn® Compression

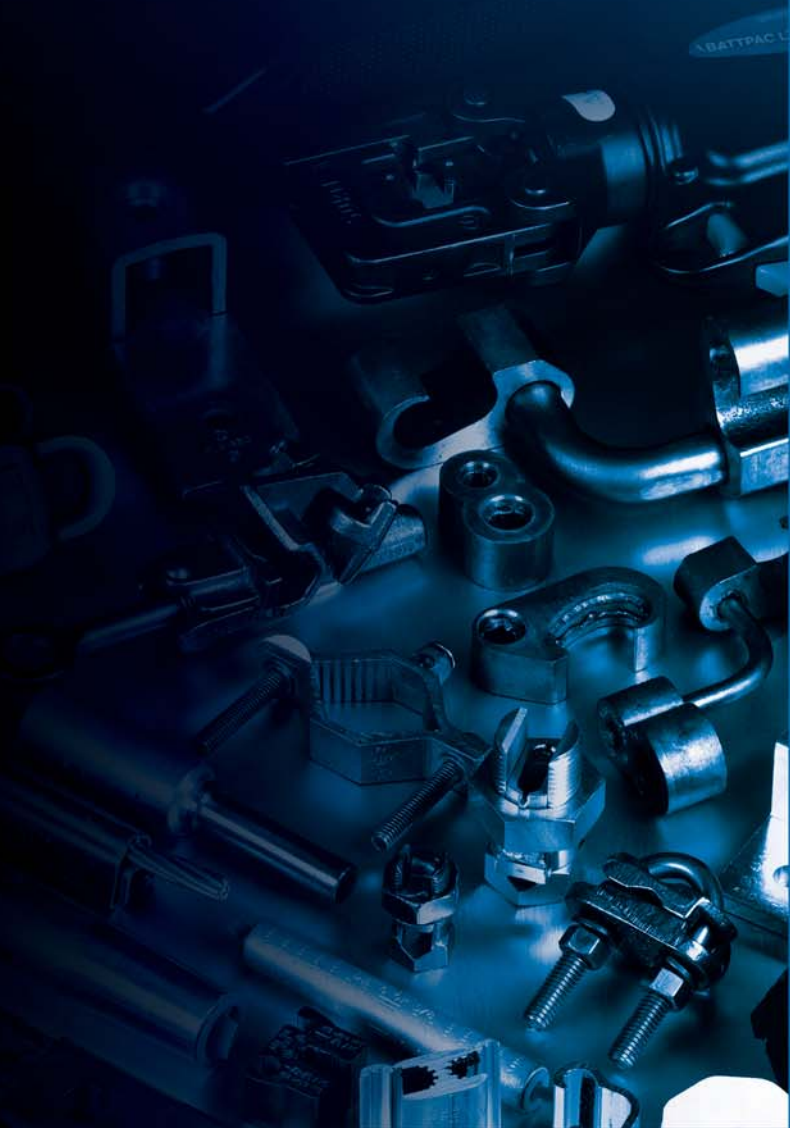

Thomas & Betts

United States
 Tel: 901.252.8000
 800.816.7809
 Fax: 901.252.1354

Technical Services
 Tel: 888.862.3289

www.tnb.com

Type CTL

Copper Short Barrel Connectors

See Pages C-3–C-5

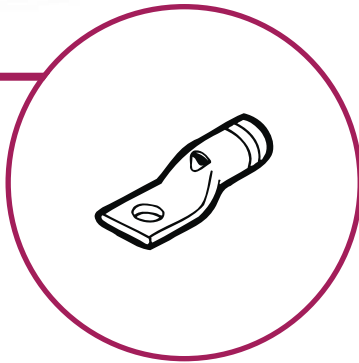

Type CTL-L, LCN

Copper Long Barrel Connectors

See Pages C-5–C-6

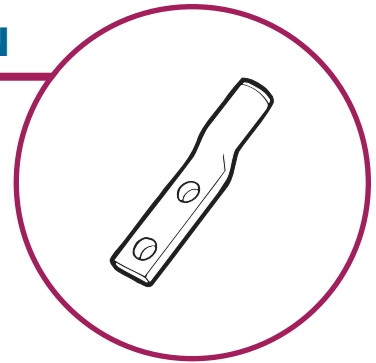

Type CSP, CU

Copper Compression Splices

See Page C-7–C-8

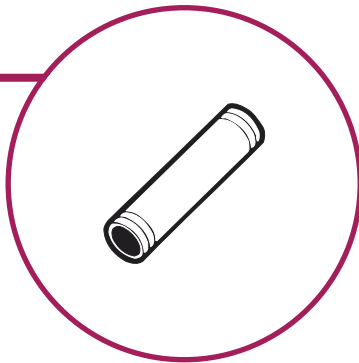

Type PA

Pin Adapter Terminals

See Page C-8

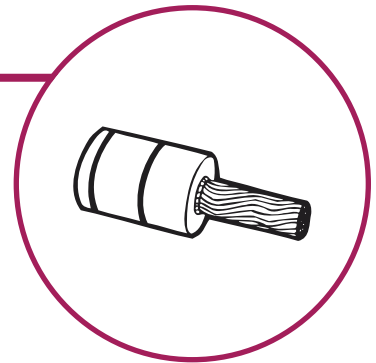

Type ATL

Aluminum Compression Connectors

See Pages C-9–C-10

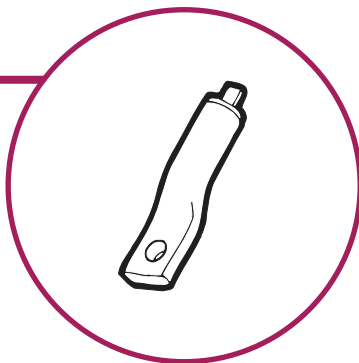

Type ASP

Aluminum Splices

See Page C-10

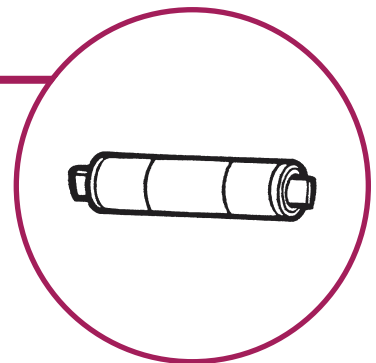



Specially designed for industrial and building applications.

Type CTL — Copper One-Hole Lugs, Short Barrel

Copper Compression Connectors

- For use with copper conductor: AWG stranded, flexible cable, welding cable and portable cord
- Specially designed for industrial and building applications
- Made of high-conductivity seamless copper tubing
- Tin-plated for corrosion resistance
- Specially chamfered barrel for ease of installation
- Color-coded for matching die identification
- Can be used for high voltage application up to 35 kV provided proper high voltage insulation techniques are used
- UL® Listed for AWG conductor when installed with Blackburn, Burndy, T&B or Anderson tools
- Comply with Subpart 111.60-17 of Federal Register's Coast Guard Electrical Engineering Rules and Regulations

Short Barrel Connectors

- Short barrel connectors designed for regular-duty applications
- Ideal for confined areas

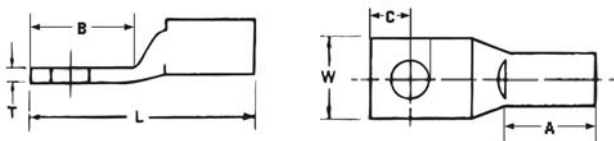

CAT. NO.	CONDUCTOR SIZE (CU)	STUD SIZE	DIMENSIONS (IN.)						DIE COLOR CODE
			A	B	C	L	W	T	
CTL8-10	8 Str.	10	13/32	1/2	7/32	17/32	3/8	1/16	RED
CTL8-14		1/4	13/32	19/32	1/4	13/16	7/16	1/16	
CTL8-516		5/16	13/32	5/8	9/32	15/16	9/16	1/16	
CTL6-10	6 Str. or #6 Weld	10	7/16	17/32	7/32	17/32	7/16	1/16	BLUE
CTL6-14		1/4	7/16	17/32	7/32	17/32	7/16	1/16	
CTL6-516		5/16	7/16	21/32	9/32	13/32	19/32	1/16	
CTL6-38		3/8	7/16	21/32	9/32	13/32	19/32	1/16	
CTL4-10	4 Str.	10	1/2	19/32	1/4	13/8	17/32	3/32	GRAY
CTL4-14		1/4	1/2	19/32	1/4	13/8	17/32	3/32	
CTL4-516		5/16	1/2	21/32	5/16	13/16	19/32	1/16	
CTL4-38		3/8	1/2	21/32	5/16	13/16	19/32	1/16	
CTL2-14	2 Str. or #3 Weld	1/4	19/32	21/32	1/4	1 1/2	9/16	3/32	BROWN
CTL2-516		5/16	19/32	7/8	3/8	1 3/32	9/16	3/32	
CTL2-38		3/8	19/32	29/32	3/8	1 1/4	9/16	3/32	
CTL2-12		1/2	19/32	1 1/16	1/2	1 29/32	3/4	1/16	
CTL1-14	1 Str. or #2 Weld	1/4	19/32	21/32	1/4	1 1/2	21/32	3/32	GREEN
CTL1-516		5/16	19/32	7/8	3/8	1 29/32	21/32	3/32	
CTL1-38		3/8	19/32	29/32	3/32	1 1/4	21/32	3/32	
CTL1-12		1/2	19/32	1 1/4	1/2	2 3/32	3/4	3/32	
CTL10-516	1/0 Str. or #1 Weld	5/16	1 1/16	7/8	3/8	1 19/16	3/4	1/8	PINK
CTL10-38		3/8	1 1/16	29/32	3/8	1 1/8	3/4	1/8	
CTL10-12		1/2	1 1/16	1 1/4	1/2	2 3/16	3/4	1/8	
CTL20-38	2/0 Str. or 1/0 Weld	3/8	1 3/16	29/32	3/8	2 1/2	13/16	1/8	BLACK
CTL30-38	3/0 Str. or 2/0 Weld	1/2	1 3/16	1 1/4	1/2	2 1/2	13/16	1/8	ORANGE
CTL30-12		1/2	1 3/16	1 1/4	1/2	2 1/2	29/32	1/8	
CTL40-38	4/0 Str. or 3/0 Weld	3/8	1 5/16	29/32	3/8	2 1/2	1 1/2	1/8	PURPLE
CTL40-12		1/2	1 5/16	1 1/4	1/2	2 1/2	1 1/2	1/8	
CTL250-12	250 kcmil or 4/0 Weld	1/2	1 1/2	1 1/4	1/2	2 1/2	1 1/8	1/8	YELLOW
CTL300-12	300 kcmil	1/2	1 1/2	1 1/4	1/2	2 5/8	1 3/16	5/32	WHITE
CTL350-12	350 kcmil	1/2	1 1/2	1 1/4	1/2	2 5/8	1 1/2	5/32	RED
CTL400-12	400 kcmil	1/2	1 1/2	1 1/4	1/2	3 1/16	1 13/32	5/32	BLUE
CTL400-58		5/8	1 1/2	1 3/16	5/8	3 1/2	1 13/32	5/32	
CTL500-12	500 kcmil	1/2	1 13/32	1 1/4	1/2	3 1/4	1 19/32	7/32	BROWN
CTL500-58		5/8	1 13/32	1 1/16	5/8	3 1/16	1 19/32	7/32	
CTL600-58	600 kcmil	5/8	1 1/16	1 3/16	5/8	3 3/32	1 3/4	7/32	GREEN
CTL750-58	750 kcmil	5/8	1 1/2	1 3/16	5/8	3 25/32	1 9/32	1/4	BLACK
CTL1000-58	1,000 kcmil	5/8	1 3/4	1 3/16	5/8	4 1/2	2 1/4	9/32	N/A

Blackburn®

Color-Coded Compression Connectors

Ideal for use in confined areas.

Type CTL — Copper Two-Hole Lugs, Short Barrel

Blackburn® Compression

- For use with copper conductor: AWG stranded, flexible cable, welding cable and portable cord
- Specially designed for industrial and building applications
- Made of high-conductivity seamless copper tubing
- Tin plated for corrosion resistance
- Specially chamfered barrel for ease of installation
- Color-coded for matching die identification
- Can be used for high-voltage application up to 35 kV provided proper high voltage insulation techniques are used
- UL® Listed for AWG conductor when installed with Blackburn, Burndy, T&B or Anderson tools
- Comply with Subpart 111.60-17 of Federal Register's Coast Guard Electrical Engineering Rules and Regulations

Short Barrel Connectors

- Short barrel connectors designed for regular-duty applications
- Ideal for confined areas

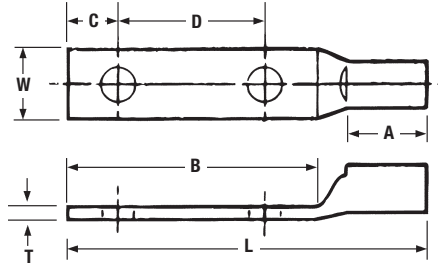

CAT. NO.	CONDUCTOR SIZE (CU)	STUD SIZE	DIMENSIONS (IN.)							DIE COLOR CODE	
			A	B	C	D	L	W	T		
CTL6-214	6 Str. or #6 Weld	1/4	1/2	1 1/4	1/4	5/8	1 3/32	1 3/32	1/16	BLUE	
CTL4-214	4 Str. or #4 Weld		1/2	1 1/4	1/4	5/8	2 1/32	1/2	3/32	GRAY	
CTL2-2516	2 Str. or #3 Weld	5/16	1 5/32	1 5/8	3/8	3/4	2 15/32	9/16	3/32	BROWN	
CTL1-2516	1 Str. or #2 Weld		1 5/32	1 1/4	3/8	7/8	2 1/32	2 1/32	3/32	GREEN	
CTL10-2516	1/0 Str. or #1 Weld		1 1/16	1 3/4	3/8	7/8	2 1/16	3/4	1/8	PINK	
CTL202	2/0 Str. or 1/0 Weld	1/2	1 3/8	2 1/16	1/2	1 1/4	3 1/16	1 3/16	1/8	BLACK	
CTL302	3/0 Str. or 2/0 Weld		2 5/32	2 1/16	1/2	1 1/4	3 1/16	1 5/16	1/8	ORANGE	
CTL402	4/0 Str. or 3/0 Weld		1 5/8	3	1/2	1 1/4	4 1/4	1 3/32	1/8	PURPLE	
CTL2502	250 kcmil or 4/0 Weld		1 1/32	3	1/2	1 1/4	4 11/32	1 1/8	5/32	YELLOW	
CTL3002	300 kcmil		1 1/32	3	1/2	1 1/4	4 11/32	1 3/16	5/32	WHITE	
CTL3502	350 kcmil		1 1/32	3	1/2	1 1/4	4 17/32	1 11/32	5/32	RED	
CTL4002	400 kcmil		1 1/32	3	1/2	1 1/4	4 15/16	1 11/32	5/32	BLUE	
CTL5002	500 kcmil		1 3/8	3	1/2	1 1/4	5	1 17/32	7/32	BROWN	
CTL6002-38	600 kcmil		3/8	1 17/32	1 23/32	3/8	1 1/4	5 1/2	1 23/32	7/32	GREEN
CTL6002-12			1 17/32	3	1/2	1 1/4	5 1/2	1 23/32	7/32	BLACK	
CTL7502	750 kcmil	1/2	1 1/2	3	1/2	1 1/4	5 3/32	1 23/32	1/4	BLACK	
CTL10002	1000 kcmil		1 3/4	3	1/2	1 1/4	5 5/32	2 1/4	5/32	N/A	



Ideal for industrial, oil rig, mining, welding and transportation electrical termination applications.

Type CTL — Copper One-Hole Lugs, Long Barrel

- For use with copper conductor: AWG stranded, flexible cable, welding cable and portable cord
- Specially designed for industrial and building applications
- Made of high-conductivity seamless copper tubing
- Tin plated for corrosion resistance
- Specially chamfered barrel for ease of installation
- Color-coded for matching die identification
- Can be used for high-voltage application up to 35 kV provided proper high-voltage insulation techniques are used
- UL® Listed for AWG conductor when installed with Blackburn, Burndy, T&B or Anderson tools
- Comply with Subpart 111.60-17 of Federal Register's Coast Guard Electrical Engineering Rules and Regulations

Long Barrel Connectors

- Ideal for industrial, oil rig, mining, welding and transportation electrical termination applications
- Heavy-duty design permits additional crimp for added mechanical strength

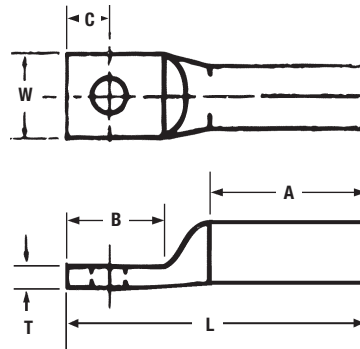

CAT. NO.	CONDUCTOR SIZE AWG	FLEXIBLE CONDUCTOR		STUD	DIMENSIONS (IN.)						DIE COLOR
CTL8L-14	8 Str.	8	37/24	1/4	25/32	5/8	1/4	1 1/8	13/32	1/16	RED
CTL6L-14	6 Str.	6	61/24		25/32	5/8	1/4	1 1/8	13/32	1/16	BLUE
CTL4L-14	4 Str.	5	91/24		25/32	5/8	1/4	1 1/16	1/2	3/32	GRAY
CTL2L-516	2 Str.	3	125/24	5/16	7/8	7/8	3/8	2 1/2	9/16	3/32	BROWN
CTL1L-516	1 Str.	2	150/24		13/32	7/8	3/8	2 3/4	2 1/32	3/32	GREEN
CTL10L-516	1/0 Str.	1	225/24		1 1/32	7/8	3/8	2 7/8	3/4	1/8	PINK
CTL20L-38	2/0 Str.	1/0	275/24	3/8	1 1/2	25/32	3/8	2 1/4	1 1/16	1/8	BLACK
CTL30L-12	3/0 Str.	2/0	325/24		1 1/8	1 1/4	1/2	2 1/16	2 3/32	1/8	ORANGE
CTL40L-12	4/0 Str.	—	—		1 1/8	1 1/4	1/2	2 1/16	1 1/2	1/8	PURPLE
CTL250L-12	250 kcmil	3/0	450/24	1/2	1 1/2	1 1/4	1/2	3 1/8	1 1/8	1/8	YELLOW
CTL300L-12	300 kcmil	4/0	550/24		1 25/32	1 1/4	1/2	3 1/32	1 3/16	1/8	WHITE
CTL350L-12	350 kcmil	263	650/24		1 27/32	1 1/4	1/2	3 1/8	1 11/32	5/32	RED
CTL400L-58	400 kcmil	313	775/24	5/8	1 27/32	1 1/16	5/8	4 1/2	1 19/32	5/32	BLUE
CTL500L-58	500 kcmil	373	925/24		2 1/32	1 1/16	5/8	4 1/2	1 19/32	3/16	BROWN
CTL600L-58	600 kcmil	444	1100/24		2 1/8	1 1/16	5/8	4 1/16	1 23/32	7/32	GREEN
CTL750L-58	750 kcmil	535	1325/24	3/4	2 1/8	1 1/16	5/8	4 23/32	1 29/32	1/4	BLACK
CTL1000L-58	1000 kcmil	646	1600/24		2 1/8	1 1/16	5/8	5 1/2	2 1/4	9/32	N/A
		777	1925/24								

Blackburn®

Color-Coded Compression Connectors

Made of high-conductivity seamless copper tubing, tin plated for corrosion resistance.



Type LCN — Copper Two-Hole Lugs, Long Barrel

Copper Compression Connectors

- For use with copper conductor: AWG stranded, flexible cable, welding cable and portable cord
- Specially designed for industrial and building applications
- Made of high-conductivity seamless copper tubing
- Tin plated for corrosion resistance
- Specially chamfered barrel for ease of installation
- Color-coded for matching die identification
- Can be used for high-voltage application up to 35 kV provided proper high-voltage insulation techniques are used

- UL Listed for AWG conductor when installed with Blackburn, Burndy, T&B or Anderson tools
- Comply with Subpart 111.60-17 of Federal Register's Coast Guard Electrical Engineering Rules and Regulations

Long Barrel Connectors

- Ideal for industrial, oil rig, mining, welding and transportation electrical termination applications
- Heavy-duty design permits additional crimp for added mechanical strength

Blackburn® Compression

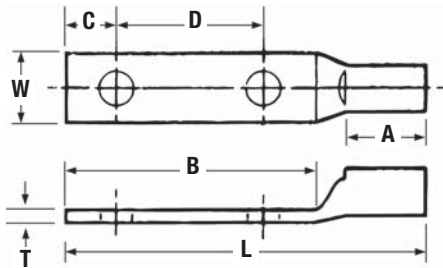

CAT. NO.	CONDUCTOR SIZE AWG (CU)	FLEXIBLE CONDUCTOR SIZE	STRANDING	STUD SIZE	DIMENSIONS (IN.)							DIE COLOR CODE
					A	B	C	D	L	W	T	
LCN8-14	8 Str.	8	37/24	1/4	5/32	1 1/16	3/4	5/8	2 1/8	1 1/32	1/16	RED
LCN6-14	6 Str.	6	61/24		5/32	1 1/4	1/4	5/8	2 1/4	1 1/32	1/16	BLUE
LCN6-12	6 Str.	6	61/24	1/2	5/32	3	1 1/2	1 1/4	4 1/2	7/8	3/32	GRAY
LCN4-14	4 Str.	5	91/24	1/4	5/32	1 1/16	3/4	5/8	2 1/16	1 1/32	3/16	BROWN
LCN4-12	4 Str.	5	91/24		1/2	5/32	3	1 1/2	1 1/4	4 1/2	7/8	3/32
LCN2-516	2 Str.	3	125/24	3/16	7/8	1 1/8	3/8	3/4	2 15/16	9/16	3/32	PINK
LCN2-12	2 Str.	3	125/24	1/2	7/8	3	1 1/2	1 1/4	4 1/4	7/8	3/32	BLACK
LCN1-516	1 Str.	2	150/24	3/16	1 1/2	1 1/8	3/8	7/8	2 3/2	2 1/2	3/32	ORANGE
LCN1-12	1 Str.	2	150/24	1/2	1 1/2	3	1 1/2	1 1/4	4 1 3/32	7/8	3/32	PURPLE
LCN10	1/0	1	225/24	1/2	1 1/2	3	1 1/2	1 1/4	3 3/2	3/4	1/8	WHITE
LCN20	2/0	1/0	275/24		1 1/2	3	1 1/2	1 1/4	3 3/2	3/4	1/8	BLACK
LCN30	3/0	2/0	325/24	1/2	1 1/2	2 15/16	1 1/2	1 1/4	4 1/16	1 15/16	1/8	ORANGE
LCN40	4/0	—	—		1 1/2	3	1 1/2	1 1/4	4 1 1/16	1 1/2	1/8	PURPLE
LCN250	250 kcmil	3/0	450/24	1/2	1 19/32	3	1 1/2	1 1/4	4 29/32	1 1/16	1/8	YELLOW
LCN300	300 kcmil	4/0	550/24		1 25/32	3	1 1/2	1 1/4	5 5/32	1 3/16	1/8	WHITE
LCN350	350 kcmil	263	650/24	1/2	1 27/32	3	1 1/2	1 1/4	5 1 1/2	1 1 1/2	5/32	RED
LCN400	400 kcmil	313	775/24		1 27/32	3	1 1/2	1 1/4	5 1/16	1 1 1/2	1/8	BLUE
LCN500	500 kcmil	373	925/24	1/2	2 1 1/2	3	1 1/2	1 1/4	5 1 1/16	1 1 1/2	3/16	BROWN
LCN600	600 kcmil	444	1100/24		2 1/2	3	1 1/2	1 1/4	5 3/4	1 2 1/2	7/32	GREEN
LCN75	750 kcmil	535	1325/24	1/2	2 1/2	3	1 1/2	1 1/4	6 1/2	1 2 1/2	1/4	BLACK
LCN99	1000 kcmil	646	1600/24		1/2	2 1/2	3	1 1/2	1 1/4	6 1 1/2	2 1/4	3/32
		777	1925/24									



Designed for regular-duty applications. Type CSP — Copper Splices, Short Barrel

Copper Compression Connectors

- For use with copper conductor: AWG stranded, flexible cable, welding cable and portable cord
- Specially designed for industrial and building applications
- Made of high-conductivity seamless copper tubing
- Tin plated for corrosion resistance
- Specially chamfered barrel for ease of installation
- Color-coded for matching die identification
- Can be used for high-voltage application up to 35 kV provided proper high-voltage insulation techniques are used
- UL Listed for AWG conductor when installed with Blackburn, Burndy, T&B or Anderson tools
- Comply with Subpart 111.60-17 of Federal Register's Coast Guard Electrical Engineering Rules and Regulations

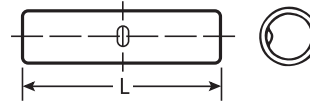

Short Barrel Connectors

- Short barrel connectors designed for regular-duty applications
- Ideal for confined areas

CAT. NO.	CONDUCTOR SIZE (CU)	LENGTH L (IN.)	DIE COLOR CODE
CSP8	8 Str.	1	RED
CSP6	6 Str.	1	BLUE
CSP4	4 Str.	1	GRAY
CSP2	3-2 Str.	1½	BROWN
CSP1	1 Str.	1½	GREEN
CSP10	1/0 Str.	1½	PINK
CSP20	2/0 Str.	1½	BLACK
CSP30	3/0 Str.	1½	ORANGE
CSP40	4/0 Str.	1½	PURPLE
CSP250	250 kcmil	2½	YELLOW
CSP300	300 kcmil	2½	WHITE
CSP350	350 kcmil	2½	RED
CSP400	400 kcmil	2½	BLUE
CSP500	500 kcmil	2½	BROWN
CSP600	600 kcmil	3	GREEN
CSP750	750 kcmil	3	BLACK
CSP1000	1000 kcmil	3½	N/A

Blackburn®

Color-Coded Compression Connectors

Heavy-duty design permits additional crimp for added mechanical strength.

Type CU — Copper Splices, Long Barrel

Copper Compression Connectors

- For use with copper conductor: AWG stranded, flexible cable, welding cable and portable cord
- Specially designed for industrial and building applications
- Made of high-conductivity seamless copper tubing
- Tin plated for corrosion resistance
- Specially chamfered barrel for ease of installation
- Color-coded for matching die identification
- Can be used for high-voltage application up to 35 kV provided proper high voltage insulation techniques are used
- UL Listed for AWG conductor when installed with Blackburn, Burndy, T&B or Anderson tools
- Comply with Subpart 111.60-17 of Federal Register's Coast Guard Electrical Engineering Rules and Regulations

Long Barrel Connectors

- Ideal for industrial, oil rig, mining, welding and transportation electrical termination applications
- Heavy-duty design permits additional crimp for added mechanical strength

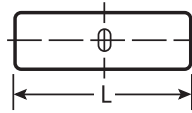

CAT. NO.	CONDUCTOR SIZE AWG (CU)	FLEXIBLE CONDUCTOR		LENGTH L (IN.)	DIE COLOR CODE
		CMA	STRANDING		
CU8	8 Str.	8	37/24	1 1/4	RED
CU6	6 Str.	6	61/24		
CU4	4 Str.	5	91/24	1 1/2	GRAY
CU2	2 Str.	3	125/24		
CU1	1 Str.	2	150/24	2	BROWN
CU10	1/0 Str.	1	225/24		
CU20	2/0 Str.	1/0	275/24	2 1/2	GREEN
CU30	3/0 Str.	2/0	325/24		
CU40	4/0 Str.	—	—	3	PINK
CU250	250 kcmil	3/0	450/24		
CU300	300 kcmil	4/0	550/24	3 1/2	BLACK
CU350	350 kcmil	263	650/24		
CU400	400 kcmil	313	755/24	4	ORANGE
CU500	500 kcmil	373	925/24		
CU600	600 kcmil	444	1100/24	4 1/2	PURPLE
CU750	750 kcmil	535	1325/24		
CU1000	1000 kcmil	646	1600/24	5	YELLOW
		777	1925/24		N/A

Insulating covers included.

Type PA — Pin Adapter Terminals

- Connector for aluminum conductor only
- Pigtail may be inserted into either aluminum or copper connectors
- 90° C rating per UL 486B
- Tin-plated stranded copper wire pigtail
- Tin-plated aluminum barrel prefilled with oxide inhibitor and capped

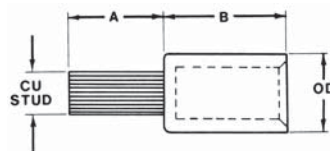
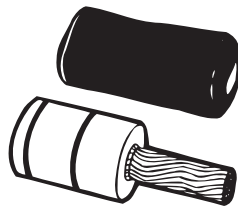

CAT. NO.	CONDUCTOR SIZE	COPPER STUD SIZE	DIMENSIONS (IN.)			DIE COLOR CODE
			A	B	O.D.	
PA06	6 Str.	8	3/8	1 1/2	.640	N/A
PA04	4 Str.	6	3/8	1 1/2	.640	
PA02	2 Str.	4	3/8	1 1/2	.640	
PA01	1 Str.	3	1	1 1/2	.640	
PA11	1/0 Str.	2	1 1/4	1 1/2	.906	RED
PA21	2/0 Str.	1	1 1/2	1 1/2	.906	
PA31	3/0 Str.	1/0	1 3/4	1 1/2	.906	
PA41	4/0 Str.	2/0	1 3/4	1 1/2	.906	BROWN
PA25	250 kcmil	3/0	1 1/2	2 1/8	1.155	
PA30	300 kcmil	4/0	1 1/2	2 1/8	1.155	
PA35	350 kcmil	4/0	1 1/2	2 1/8	1.155	PINK
PA40	400 kcmil	250 kcmil	1 1/2	2 3/8	1.375	
PA50	500 kcmil	350 kcmil	1 1/2	2 3/8	1.375	
PA60	600 kcmil	350 kcmil	1 1/2	2 3/4	1.500	YELLOW
PA75	750 kcmil	500 kcmil	2	2 3/4	1.500	

UL Listed AL9CU.

Blackburn® Compression

Thomas & Betts

www.tnb.com

United States
Tel: 901.252.8000
800.816.7809
Fax: 901.252.1354

Technical Services
Tel: 888.862.3289



Use with aluminum or copper conductor.

Type ATL — Aluminum One-Hole Lugs

- Specifically designed for use with aluminum conductor (concentric, compressed or compact)
- Also listed for use with copper conductor
- Made of high-conductivity seamless aluminum tubing
- Tin plated for corrosion resistance
- Chamfered barrels for ease of installation
- Can be used for high-voltage application up to 35 kV, provided high-voltage insulation techniques are used
- Color-coded for quick, easy die identification
- Prefilled with oxide inhibiting compound
- UL Listed when installed with Blackburn, Burndy, T&B or Anderson tools

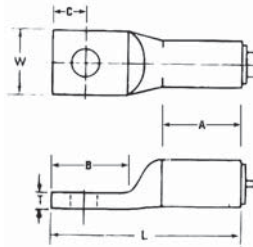

Blackburn® Compression

CAT. NO.	CONDUCTOR SIZE (AL OR CU)	STUD SIZE	DIMENSIONS (IN.)						DIE COLOR CODE
			A	B	C	L	W	T	
ATL8-10	8 Str.	10	1/2	19/32	7/32	1 1/32	1 1/32	3/32	BLUE
ATL8-14		10	1/2	11/16	1 1/32	1 1/2	7/16	3/32	
ATL6-10	6 Str.	10	25/32	9/16	7/32	1 1/2	1 1/32	1/8	GRAY
ATL6-14		10	1/4	25/32	23/32	15/32	1 23/32	15/32	
ATL6-38	4 Str.	3/8	27/32	29/32	7/16	1 27/32	5/8	3/32	GREEN
ATL4-14		1/4	27/32	19/16	1 1/32	1 29/32	3/8	3/16	
ATL4-516	4 Str.	5/16	27/32	1	7/16	2 1/16	3/8	3/16	GREEN
ATL4-38		3/8	27/32	29/32	7/16	2	3/8	3/16	
ATL2-14	2 Str.	1/4	27/32	29/32	1 1/32	1 15/16	2 3/32	3/16	PINK
ATL2-516		5/16	27/32	7/8	7/16	2 1/32	3/4	3/16	
ATL2-38	1 Str.	3/8	27/32	29/32	7/16	2 1/16	2 3/32	3/16	GOLD
ATL1-516		5/16	27/32	7/8	7/16	2 1/32	2 3/32	3/16	
ATL1-38	1 Str.	3/8	27/32	29/32	7/16	2 3/8	3/4	3/16	GOLD
ATL10-516		5/16	1 1/32	1	7/16	2 1/32	7/8	3/16	
ATL10-38	1/0 Str.	3/8	1 1/32	1 1/16	7/16	2 19/32	7/8	3/16	TAN
ATL10-12		1/2	1 1/32	1 3/8	1 1/16	2 5/16	1 5/16	3/16	
ATL20-38	2/0 Str.	3/8	1 1/16	1	7/16	2 3/8	3 3/32	7/32	OLIVE
ATL20-12		1/2	1 3/16	1 3/8	1 1/16	3	1 1/32	1/32	
ATL30-38	3/0 Str.	3/8	1 11/32	1 1/16	7/16	2 5/16	1 1/16	7/32	RUBY
ATL30-12		1/2	1 11/32	1 3/8	1 1/16	3 3/8	1 1/16	7/32	
ATL40-38	4/0 Str.	3/8	1 7/8	1 3/32	3/8	3 3/4	1 3/16	1/4	WHITE
ATL40-12		1/2	1 7/8	1 3/4	1/2	3 3/8	1 3/16	1/4	
ATL250-12	250 kcmil	1/2	2 1/32	1 1/4	1/2	4 1/32	1 1/32	1/4	RED
ATL300-38	300 kcmil	3/8	2	1 5/16	3/8	4 3/16	1 3/8	3/32	BLUE
ATL300-12		1/2	2	1 9/16	1/2	4 3/16	1 3/8	3/32	
ATL350-12	350 kcmil	1/2	2 1/16	1 3/16	1/2	4 3/8	1 1/8	3/16	BROWN
ATL400-58	400 kcmil	5/8	2 1/16	1 1/4	1/2	4 5/16	1 1/8	3/8	GREEN
ATL500-12	500 kcmil	1/2	2 1/16	1 1/4	1/2	4 5/16	1 5/32	3/8	PINK
ATL500-58		3/8	2 1/16	2	3/4	5 1/16	1 29/32	3/8	
ATL600-12	600 kcmil	1/2	2 1/16	2	3/4	5 1/16	1 29/32	1 1/32	BLACK
ATL750-12	750 kcmil	1/2	2 3/8	1 1/4	1/2	5 1/4	2 1/8	3/8	N/A
ATL750-58		3/8	2 3/8	2	3/4	6 1/32	2 1/8	3/8	

Blackburn®

Color-Coded Compression Connectors

Blackburn® Compression

Made of high-conductivity seamless aluminum tubing, tin-plated for corrosion resistance.

Type ATL — Aluminum Two-Hole Lugs

- Specifically designed for use with aluminum conductor (concentric, compressed or compact)
- Also listed for use with copper conductor
- Made of high-conductivity seamless aluminum tubing
- Tin plated for corrosion resistance
- Chamfered barrels for ease of installation
- Can be used for high-voltage application up to 35 kV, provided high-voltage insulation techniques are used
- Color-coded for quick, easy die identification
- Prefilled with oxide inhibiting compound
- UL Listed when installed with Blackburn, Burndy, T&B or Anderson tools

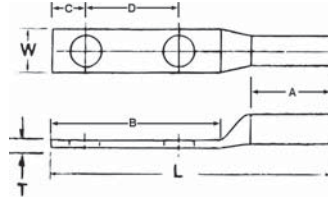

CAT. NO.	CONDUCTOR SIZE (CU)	STUD SIZE	DIMENSIONS (IN.)							DIE COLOR CODE
			A	B	C	D	L	W	T	
ATL102-38	1/0 Str.	½	1½	2⅙	¾	1	3⅝	⅞	⅜	TAN
ATL102			1⅞	3	½	1¼	4⅞	1⅝	⅜	
ATL202	2/0 Str.		1⅞	3¾	¾	1¼	5	3⅝	⅞	OLIVE
ATL302	3/0 Str.		1⅞	3¾	¾	1¼	5½	1⅞	⅞	RUBY
ATL402	4/0 Str.		1⅞	3	½	1¼	5½	1⅞	¼	WHITE
ATL2502	250 kcmil		2⅝	3	½	1¼	5⅝	1⅞	¼	RED
ATL3002	300 kcmil		2	3	½	1¼	5½	1⅞	⅝	BLUE
ATL3502	350 kcmil		2⅞	3	½	1¼	6⅞	1⅞	⅝	BROWN
ATL4002	400 kcmil		2⅞	3	½	1¼	6⅞	1⅞	⅝	GREEN
ATL5002	500 kcmil		2⅞	3	½	1¼	6⅞	1⅞	⅝	PINK
ATL6002	600 kcmil		2⅞	3	½	1¼	6⅞	1⅞	1⅝	BLACK
ATL7502	750 kcmil		2⅞	3	½	1¼	7	2⅞	⅝	N/A

Chamfered barrels enable easier installation.

Type ASP – Aluminum Splices



- Specifically designed for use with aluminum conductor (concentric, compressed or compact)
- Also listed for use with copper conductor
- Made of high-conductivity seamless aluminum tubing
- Tin plated for corrosion resistance
- Chamfered barrels for ease of installation
- Can be used for high-voltage application up to 35 kV, provided high-voltage insulation techniques are used
- Color-coded for quick, easy die identification
- Prefilled with oxide inhibiting compound
- UL Listed when installed with Blackburn, Burndy, T&B or Anderson tools

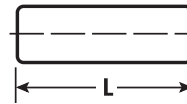

CAT. NO.	CONDUCTOR SIZE (AL OR CU)	LENGTH L (IN.)	DIE COLOR CODE
ASP8	8 Str.	1¼	BLUE
ASP6	6 Str.	1½	GRAY
ASP4	4 Str.	1¾	GREEN
ASP2	2 Str.	1⅞	PINK
ASP1	1 Str.	2	GOLD
ASP10	1/0 Str.	2½	TAN
ASP20	2/0 Str.	2½	OLIVE
ASP30	3/0 Str.	2½	RUBY
ASP40	4/0 Str.	3¼	WHITE
ASP250	250 kcmil	4	RED
ASP300	300 kcmil	4	BLUE
ASP350	350 kcmil	3¾	BROWN
ASP400	400 kcmil	4¾	GREEN
ASP500	500 kcmil	5	PINK
ASP600	600 kcmil	5½	BLACK
ASP750	750 kcmil	5¾	N/A
ASP1000	1,000 kcmil	6	N/A

Thomas & Betts

United States
Tel: 901.252.8000
800.816.7809
Fax: 901.252.1354

Technical Services
Tel: 888.862.3289

Tool and Die Index for Color-Coded Compression Connectors



Short Barrel — Types CTL, CTL-2 and CSP

COPPER STRAND WIRE SIZE	DIE COLOR CODE	BLACKBURN TOOLS						BURNDY TOOLS				T&B TOOLS					ANDERSON TOOLS				
		MECH. OD58	CRIMPS PER END	MECH. NRG 2506	CRIMPS PER END	HYD. JB12B*	CRIMPS PER END	MECH. MY29-3	CRIMPS PER END	HYD. Y35, Y39, Y46	CRIMPS PER END	MECH. TBM5S	CRIMPS PER END	MECH. TBM8S	CRIMPS PER END	HYD. TBM15	CRIMPS PER END	CU WIRE RANGE	VC6 [†] VC6FT CRIMPS PER END	VC7 [†] VC7FT CRIMPS PER END	VC8C ^{††} VC8FT CRIMPS PER END
8	RED	½	3	**	1	B71CH	1	**	1		13454	2	13461	2	21	2					
6	BLUE	J ¼	3	**	1	B73CH	1	**	1	U5CRT	2	13454	2	13461	2	24	2				
4	GRAY	⅝	3	**	1	B74CH	1	**	1	U4CRT	2	13454	2	13461	2	29	2				
3	WHITE			**	2			**	2	U3CRT	2										
2	BROWN	⅜	4	**	2	B75CH	1	**	2	U2CRT	2	13454	2	13461	2	33	2	6-2	1*	2	
1	GREEN	P	4	**	2	B05CH	1	**	2	U1CRT	2	13455	3	13462	3	37	2	6-1	1	2	
1/0	PINK	½	4	**	2	B06CHI	2	**	2	U25RT	2	13455	3	13462	3	42H	3	6-1/0	1	2	
2/0	BLACK	⅞	4	**	2	B72CH	1	**	2	U26RT	2	13455	3	13462	3	45	2	4-2/0	1	2	
3/0	ORANGE	⅞	4	**	2	B08CH	1	**	2	U27RT	2	13455	4	13462	4	50	2	2-3/0	2	2	
4/0	PURPLE	¾-1	4	**	2	B09CH	2	**	2	U28RT	2	13456	4	13463	4	54H	3	1-4/0	2	2	
250	YELLOW	⅞	4	**	2	B26CH	2	**	2	U29RT	2	13456	4	13463	4	62	2	1/0-250 [†]	2	2	
300	WHITE					B10CHI B10CH	2			U30RT	2			13465	4	66	2	2/0-300 [†]	2	2	
350	RED					B11CH	2			U31RT	2			13465	4	71H	3	3/0-350 [†]	2	3	
400	BLUE					B11CH	2			U32RT	3			13467	4	76	2	4/0-400 [†]	2	3	
500	BROWN					B12CHI B12CH	2			U34RT	3			13468	5	87H	3	4/0-500V	2	3	
600	GREEN					B36CH ¹	3			U36RT ³	3					94H	3	250-600	3	VC7FT only	
750	BLACK					B39CH ¹ 6039RT ²	3 1			U39RT ³	3					106H	3	500-750	4	VC7FT only	2
1000	—					6044RT ²	1			P44RT ⁴	4					125H	4	750-1000			2

Long Barrel — Types CTL-L, LCN and CU

COPPER STRAND WIRE SIZE	DIE COLOR CODE	BLACKBURN TOOLS						BURNDY TOOLS				T&B TOOLS					ANDERSON TOOLS				
		MECH. OD58	CRIMPS PER END	MECH. NRG 2506	CRIMPS PER END	HYD. JB12B*	CRIMPS PER END	MECH. MY29-3	CRIMPS PER END	HYD. Y35, Y39, Y46	CRIMPS PER END	MECH. TBM5S	CRIMPS PER END	MECH. TBM8S	CRIMPS PER END	HYD. TBM15	CRIMPS PER END	CU WIRE RANGE	VC6 [†] VC6FT CRIMPS PER END	VC7 [†] VC7FT CRIMPS PER END	VC8C ^{††} VC8FT CRIMPS PER END
8	RED	½	4	**	2	B71CH	2	**	2		13454	2	13461	2	21	3					
6	BLUE	J ¼	4	**	2	B73CH	2	**	2	U5CRT	2	13454	2	13461	2	24	3				
4	GRAY	⅝	4	**	2	B74CH	2	**	2	U4CRT	2	13454	2	13461	2	29	3				
3	WHITE			**	3			**	3	U3CRT	2										
2	BROWN	⅜	5	**	3	B75CH	2	**	3	U2CRT	2	13454	2	13461	2	33	3	6-2	2	4	
1	GREEN	P	5	**	3	B05CH	2	**	3	U1CRT	2	13455	4	13462	3	37	3	6-1	2	5	
1/0	PINK	½	5	**	3	B06CHI	2	**	3	U25RT	2	13455	4	13462	4	42H	4	6-1/0	2	5	
2/0	BLACK	⅞	5	**	3	B72CH	2	**	3	U26RT	2	13455	4	13462	4	45	3	4-2/0	2	5	
3/0	ORANGE	⅞	5	**	4	B08CH	2	**	4	U27RT	3	13455	6	13462	6	50	3	2-3/0	3	6	
4/0	PURPLE	¾-1	6	**	4	B09CH	3	**	4	U28RT	3	13456	6	13463	6	54H	5	1-4/0	3	6	
250	YELLOW	⅞	6	**	4	B26CH	3	**	4	U29RT	3	13456	6	13463	6	62	3	1/0-250	3	6	
300	WHITE					B10CHI B10CH	3			U30RT	3			13465	6	66	3	2/0-300	3	6	
350	RED					B11CH	3			U31RT	4			13465	6	71H	4	3/0-350	3	6	
400	BLUE					B11CH	4			U32RT	4			13467	6	76	3	4/0-400	3	6	
500	BROWN					B12CHI B12CH	4			U34RT	5			13468	8	87H	4	4/0-500	3	6	2 ^{†††}
600	GREEN					B36CH ¹	6			U36RT ³	5					94H	4	250-600	8	VC7FT only	3 ^{††††}
750	BLACK					B39CH ¹ 6039RT ²	6 2			U39RT ³	6					106H	6	500-750	9	VC7FT only	4
1000	—					6044RT ²	2			P44RT ⁴	6					125H	5	750-1000			2

* CSA Listed range 4-2 with YC6 and VC6FT

** Adjustable Indent Tool. No insert dies required

• JB12A, JB12B, HCT1239, HCT7508-12, HCT7508H

¹ HCT7508-12, HCT1239, HCT7508H only

² JB60A, JB60B only

³ Y39, Y46 only

⁴ Y46 only

[†] Users of VC6 and VC7 tools must strip off an extra 1/8" of insulation from end of conductor sizes 250 MCM and larger on CU connectors

^{††} Also use VC8 tool with aluminum nibs

^{†††} VC8 tool crimps 500 MCM only

^{††††} VC8 tool crimps 500-600 MCM only

For Flexible Rope Stranded or Flexible Stranded Tinned Copper Locomotive Conductor, Welding Cable and Portable Cord

Short Barrel — Types CTL, CTL-2 and CSP

CONDUCTOR TYPE					BLACKBURN TOOLS			BURNDY TOOLS				T&B TOOLS		ANDERSON TOOLS			
LOCOMOTIVE		WELDING	PORTABLE	STRANDED	DIE	HYD.	CRIMPS	MECH.	CRIMPS	HYD.	CRIMPS	HYD.	CRIMPS	CU WIRE	VC6 [†]	VC7 [†]	VC8C ^{††}
SIZE	STANDING	CABLE	CORD	CU AWG SIZE													
					COLOR CODE					Y39				LOCOMOTIVE			
										Y46				CABLE	CRIMPS PER END	CRIMPS PER END	CRIMPS PER END
6	37/24	—	8	8	RED	B71CH	1	**	1	—	—	21	2				
6	61/24	6	6	6	BLUE	B73CH	1	**	1	U5CD-1 Y34PR ³	1	24	2				
5	91/24			4	GRAY	B74CH	1	**	1	U4CD-1 Y34PR	1	29	2				
4	105/24	4	4	3	WHITE			**	2	U3CD-1 Y34PR	1						
3	125/24	3	3	2	BROWN	B75CH	1	**	2	U2CD-1 Y34PR	1	33	2	4-3	1	2	
2	150/24	2	2	1	GREEN	B05CH	1	**	2	U1CD-1 Y34PR	1	37	2	4-2	1	2	
1	225/24	1	1	1/0	PINK	B06CH	2	**	2	U250-1 Y34PR	1	42H	3	4-1	1	2	
1/0	275/24	1/0	1/0	2/0	BLACK	B72CH	1	**	2	U26CD-1 Y34PR	1	45	2	4-1/0	1	2	
2/0	325/24	2/0	2/0	3/0	ORANGE	B08CH	1	**	2	U270-1 Y34PR	2	50	2	2-2/0	2	2	
—	—	3/0	3/0	4/0	PURPLE	B09CH	2	**	2	U280-1 Y34PR	2	54H	3				
3/0	450/24	4/0		250	YELLOW	B26CH	2	**	2	U290-1 Y34PR ³	2	62	2	1/0-3/0 [†]	2	2	
4/0	550/24		4/0	300	WHITE	B12CH B12CH	2			U300-1 Y34PR ³	2	66	2	2/0-4/0 [†]	2		
263	650/24			300	RED	B11CH	2			U310-1 Y34PR ³	2	71H	3	3/0-263 [†]	2	3	
313	775/24			400	BLUE	B11CH	2			Y320-1 Y34PR ³	2	76	2	4/0-313V	2	3	
373	925/24			500	BROWN	B10CH B10CH	2			U340-1 Y34PRV		87H	3	4/0-373 [†]	2	3	2 ^{††}
444	1100/24			600	GREEN	B36CH	3			C360 Y46PR ⁴	2	94H	3	262-444		3 VC7FT Only	2 ^{††}
535	1325/24			750	BLACK	B39CH ¹ 6039RT ²	1			C390 Y46PR ⁴	2	106H	3	373-535		4 VC7FT Only	2
646	1600/24				—					C440	2	125H	4	535-777			2
777	1925/24			1000	—	6044RT ²	1			Y46PR4							

** Adjustable Indent Tool. No insert dies required

* JB12A, JB12B, HCT7508-12, HCT7508H, HCT1239

¹ HCT7508-12, HCT7508H, HCT1239 only

² JB60A, JB60B only

³ Y39 only

⁴ Y48B only

† User of VC6 and VC7 tools must strip off an extra 1/8" of insulation from end of cable to permit removal of tool over conductor sizes 250 MCMIL and larger on CSP connectors

†† Also use VC8 tool with aluminum nibs

††† VC8 tool crimps 500 KCMIL only

Tool and Die Index for Color-Coded Compression Connectors

For Flexible Rope Stranded or Flexible Stranded Tinned Copper Locomotive Conductor Welding Cable and Portable Cord

Long Barrel — Types CTL-L, LNC and CU

CONDUCTOR TYPE					BLACKBURN TOOLS		BURNDY TOOLS				T&B TOOLS		ANDERSON TOOLS				
LOCOMOTIVE		WELDING	PORTABLE	STRANDED	DIE COLOR CODE	HYD. JB12B*	CRIMPS PER END	MECH. MY29-11	CRIMPS PER END	HYD. Y35 Y39 Y46	CRIMPS PER END	HYD. TBM15	CRIMPS PER END	CU WIRE RANGE FOR LOCOMOTIVE CABLE	VC6† VC6FT	VC7† VC7FT	VC8‡ VC8FT
SIZE	STANDING	CABLE	CORD	CU AWG SIZE													
8	37/24	—	8	8	RED	B71CH	2	**	2	—	—	21	3				
6	61/24	6	6	6	BLUE	B73CH	2	**	2	U5CD-1 Y34PR‡	2	24	3				
6	91/24			4	GRAY	B74CH	2	**	2	U4CD-1 Y34PR	2	29	3				
4	105/24	4	4	3	WHITE			**	3	U3CD-1 Y34PR	2						
3	125/24	3	3	2	BROWN	B75CH	2	**	3	U2CD-1 Y34PR	2	33	3	4-2	2	4	
2	150/24	2	2	1	GREEN	B05CH	2	**	3	U1CD-1 Y34PR	2	37	3	4-2	2	5	
1	225/24	1	1	1/0	PINK	B06CHI	3	**	3	U250-1 Y34PR	2	42H	4	4-1	2	5	
1/0	275/24	1/0	1/0	2/0	BLACK	B72CH	2	**	3	U26CD-1 Y34PR	2	45	3	4-1/0	2	5	
2/0	325/24	2/0	2/0	3/0	ORANGE	B08CH	2	**	4	U270-1 Y34PR	2	50	3	2-2/0	3	6	
—	—	3/0	3/0	4/0	PURPLE	B09CH	3	**	4	U280-1 Y34PR	3	54H	5				
3/0	450/24	4/0		250	YELLOW	B26CH	3	**	4	U290-1 Y34PR‡	3	62	3	1/0-3/0†	3	6	
4/0	550/24		4/0	300	WHITE	B12CHI B12CH	3			U300-1 Y34PR‡	3	66	3	2/0-4/0†	3	6	
263	650/24			350	RED	B11CH	3			U310-1 Y34PR‡	3	71H	4	3/0-263†	3	6	
313	775/24			400	BLUE	B11CH	2			Y320-1 Y34PR‡	3	76	3	4/0-313†	3	6	
373	925/24			500	BROWN	B2CHI B12CH	4			U340-1 Y34PR‡		87H	3	4/0-373V	3	6	3†††
444	1100/24			600	GREEN	B36CH	6			C360 Y46PR‡	2	94H	4	262-444		8 VC7FT Only	3†††
535	1325/24			750	BLACK	B39CH† 6039RT‡	2			C390 Y48PR‡	2	106H	6	373-535		9 VC7FT Only	4
646 777	1600/24 1925/24			1000	—	6044RT‡	2			C440 Y46PR‡	2	125H	5	535-777			4
1111	2750/24			1500	—	6030AH‡	2			C460 Y46PR‡	2	—	—	1111	—	—	4

** Adjustable Indent Tool. No insert dies required

* JB12A, JB12B, HCT7508-12, HCT7508H, HCT1239

† HCT7508-12, HCT7508H, HCT1239 only

‡ JB60A, JB60B only

§ Y39 only

¶ Y48B only

†† User of VC6 and VC7 tools must strip off an extra 1/8" of insulation from end of cable to permit removal of tool over conductor sizes 250 MCML and larger on CSP connectors

††† Also use VC8 tool with aluminum nibs

†††† VC8 tool crimps 500 KCML only

One and Two Hole Lugs, Splices — Types ATL and ASP

AL OR CU STRAND WIRE SIZE	DIE COLOR CODE	BLACKBURN TOOLS						BURNDY TOOLS				T&B TOOLS					ANDERSON TOOLS			
		MECH. OD58	CRIMPS PER END	MECH. NRG 2506	CRIMPS PER END	HYD. JB12B*	CRIMPS PER END	MECH. MY29-3	CRIMPS PER END	HYD. Y35, Y39	CRIMPS PER END	MECH. TBM5S	CRIMPS PER END	MECH. TBM6S	CRIMPS PER END	HYD. TBM15	CRIMPS PER END	AL OR CU WIRE RANGE	VC6 [†] VC6FT CRIMPS PER END	VC8C
8	BLUE	¼	2	**	1	B73CH	1	**	1	U8CABT	1	13454	2	13461	2	24	2			
6	GRAY	⅜	2	**	1	B74CH	1	**	1	U6CABT	2	13454	2	13461	2	29	2			
4	GREEN	P	3	**	2	B05CH	1	**	2	U4CABT	2	13455	2	13462	2	37	2			
2	PINK	½	4	**	2	B06CHI	2	**	2	U2CABT	2	13455	3	13462	3	42H	3	6-2	2	
1	GOLD	½-1	3	**	2	B06CHI	2	**	2	U1CABT	2	13455	3	13464	3	45	2	4-1	2	
1/0	TAN	⅝	4	**	2	B06CH	2	**	2	U25ART	2	13457	3	13464	3	50	2	6-1/0	2	
2/0	OLIVE	⅝-1	4	**	2	B09CH	2	**	2	U26ART	2	13457	3	13464	3	54H	3	4-2/0	2	
3/0	RUBY	688	5	**	2	B26CH	2	**	2	U27ART	2	13457	3	13464	3	60	2	4-3/0	2	
4/0	WHITE	781	5	**	2	B10CHI	2	**	2	U28ART	2	13457	3	13465	4	66	3	2-4/0	2	
250	RED	781	5	**		B11CH	3	**	2	U29ART	2	13473	4	13466	5	71H	4	1/0-250†	2	
300	BLUE	840				B11CH	3			U30ART	2					76	2	1/0-300†		
350	BROWN					B12CHI	4			U31ART	2		13468	7	87H	4		2/0-350†	2	
400	GREEN					B36CH	6			U32ART	4				94	2		3/0-400†	2	
500	PINK					B76CH	4			U34ART	4				99H	4		4/0-500†	2	
600	BLACK					6039RT [†]	2			U36ART	4				106	2		350-600 AL 350-600 CU	3 ^{††}	
750						6024AH [†]	1	U39RT2 [‡]	4	U39ART-2 [‡]	4				125H	5		500-750 AL 600 CU		2 ^{†††}
1000	—					6030AH [†]	2	P44ART [‡]	3						150H	5		750-1000 AL		2 ^{†††}

• JB12A, JB12B, HCT7508-12, HCT1239

** Adjustable Indent Tool. No insert dies required

[†] JB60A, JB60B only

[‡] Y46 only

[‡] Y39 only

[†] Users of VC6 and VC7 tools must strip off an extra 1/8" of insulation from end of cable to permit removal of tool over conductor sizes 250 MCM and larger on CU connectors

^{††} VC6FT tool only

^{†††} With AL nibs for VC8C